

Black history timeline

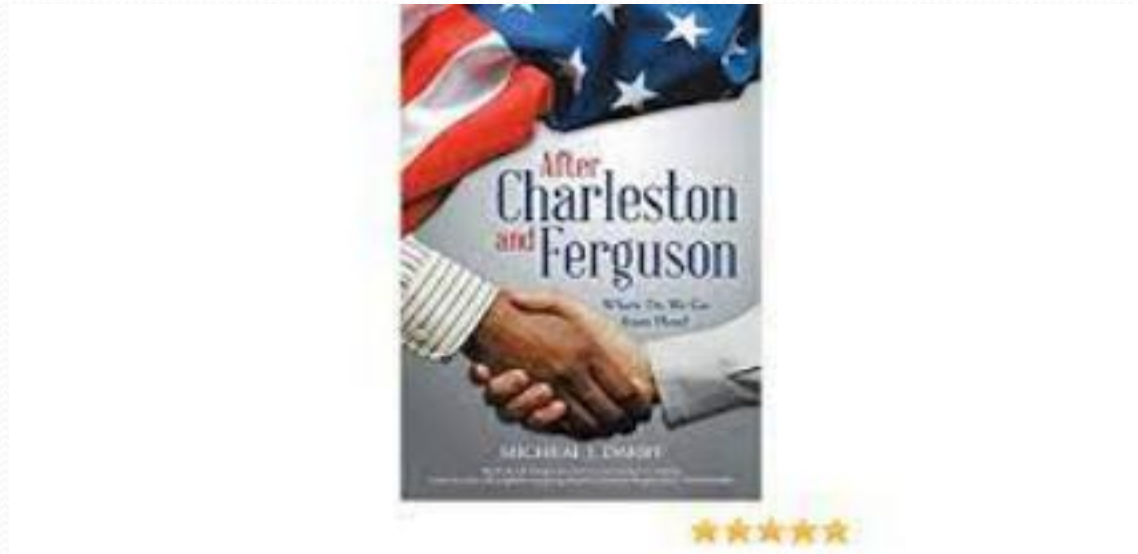

All pictures in art were taken from Google images copyrighted material
Michael J Darby jonah68@gmail.com phone number 910 352 8943

Black history PowerPoint table of contents

- A. Slavery timeline slides 2-30
- B. Early black political power slides 31-36
- C. Political and Generational wealth roadblocks slide 37-49
- D. Major black leaders slides 49-108
- E. Famous black inventors slides 109-131
- F. Modern civil rights movement slides 132-157
- G. Tragic events and the killing of black Americans that affected race relation slides 158-167
- H. A closer look at the institutions that impact black Americans slides 168-173

The first black slaves in an American colony

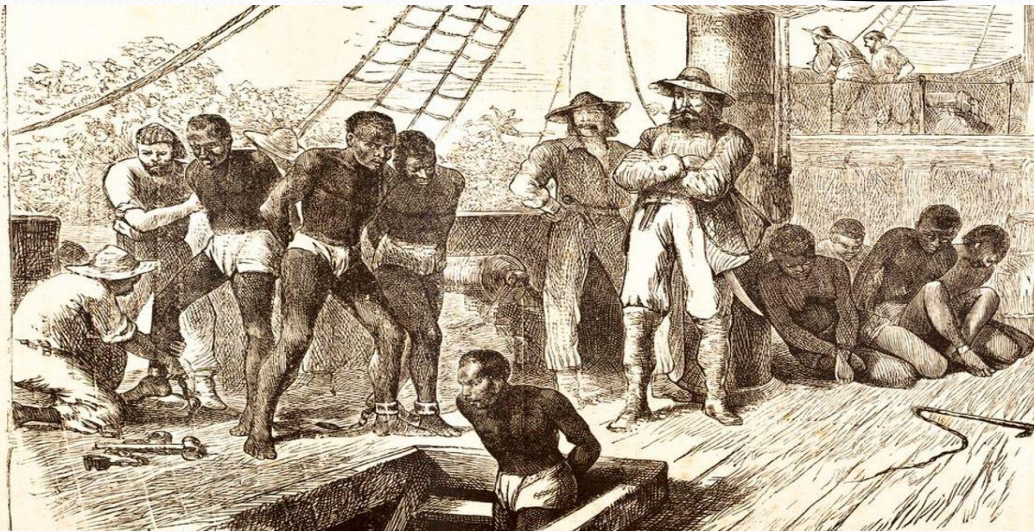

- Hundreds of thousands of Africans, both free and enslaved, aided the establishment and survival of colonies in the Americas and the New World.
- Many consider a significant starting point to slavery in America to be 1619, when the privateer The White Lion brought 20 enslaved African ashore in the British colony of Jamestown, Virginia. The crew had seized the Africans from the Portuguese slave ship Sao Jao Baptista.

Why did slavery begin?



- As labor demand grew, so did the cost of indentured servants. Many landowners also felt threatened by newly freed servants' need for land.
- The colonial elite realized the problems of indentured servitude.
- Landowners turned to enslaved Africans as a more profitable and ever-renewable source of labor, and the shift from indentured servants to racial slavery had begun.

How many slaves were brought to America?

The Trans-Atlantic Slave Trade Uprooted Millions

Number of enslaved Africans arriving on the American continent (1514-1866)



statista archive

- Though it is impossible to give accurate figures, some historians have estimated that 6 to 7 million enslaved people were imported to the New World during the 18th century, depriving the African continent of some of its

Where did most of the American slaves come from?

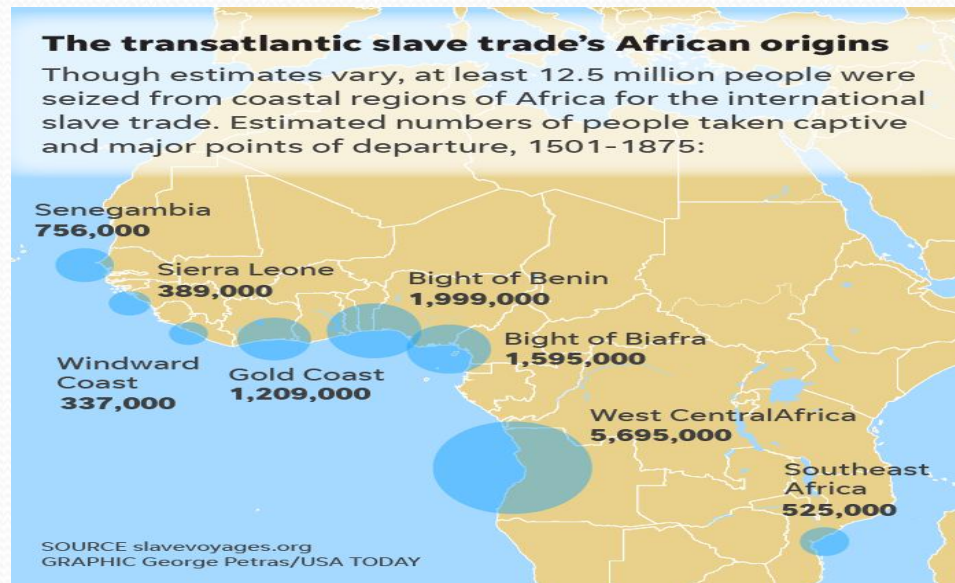

- **The majority of those enslaved and transported in the transatlantic slave trade were people from Central and West Africa that had been sold by other West Africans to**

What were the conditions of the slaves on the slave ships?

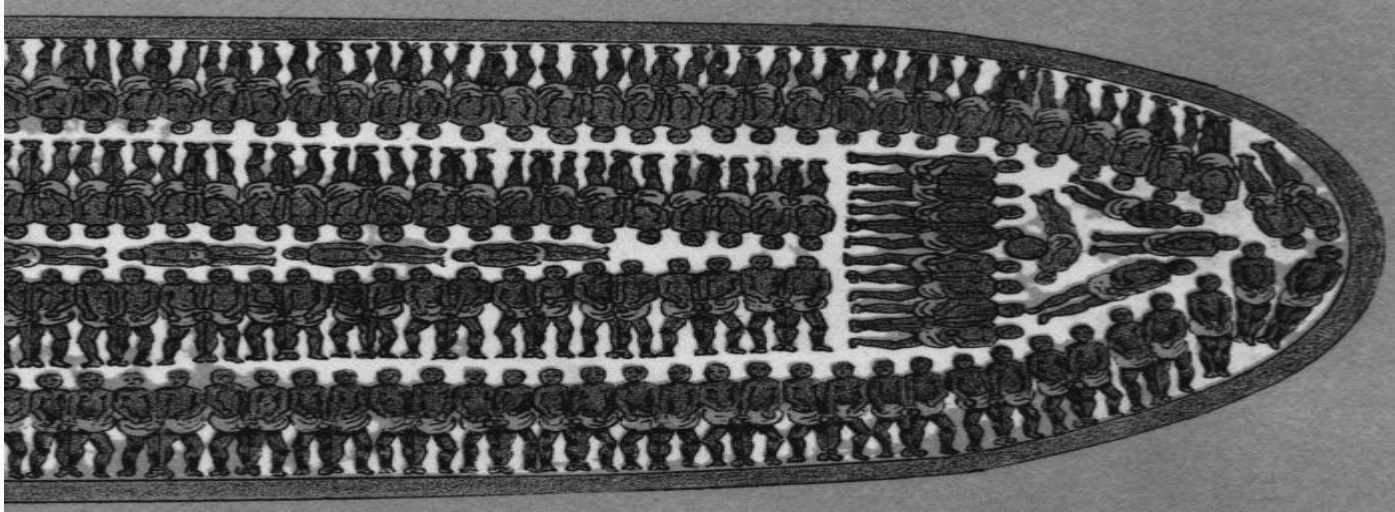

- **Seasickness was expected, and the heat was oppressive. The lack of sanitation and suffocating conditions meant a constant threat of disease.**
- **Epidemics of fever, dysentery (the 'flux'), and smallpox were frequent.**

What were the conditions on the average plantation?



- **Life on the fields meant working sunup to sundown six days a week and having food sometimes not suitable for an animal to eat.**
- **Plantation slaves lived in small shacks with a dirt floor and little or no furniture.**

For taxation purposes 3/5 of the slave population were counted for taxation

Three-Fifths Compromise

- States in the North and in the South could not agree on how slaves would be counted in the population.
- It was decided that every 5 slaves would count as 3 people for taxation and representation purposes.



Three-fifths compromise, a compromise agreement between delegates from the Northern and the Southern states at the United States Constitutional Convention (1787) that three-fifths of the

Slave uprisings Nat Turner

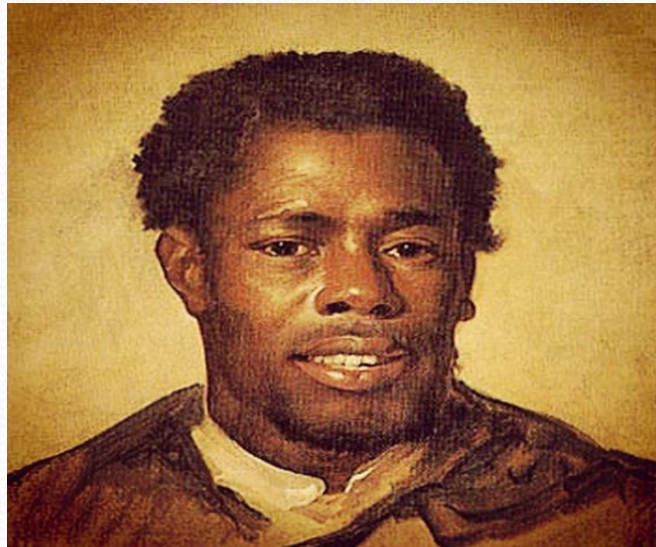

- The revolt that most terrified enslavers was that led by Nat Turner in Southampton County, Virginia, in August 1831.
- Turner's group, which eventually numbered around 75 Black men, murdered some 55-white people two days before local white people's armed resistance and the arrival of state militia forces overwhelmed them.

Slave and Free State agreement

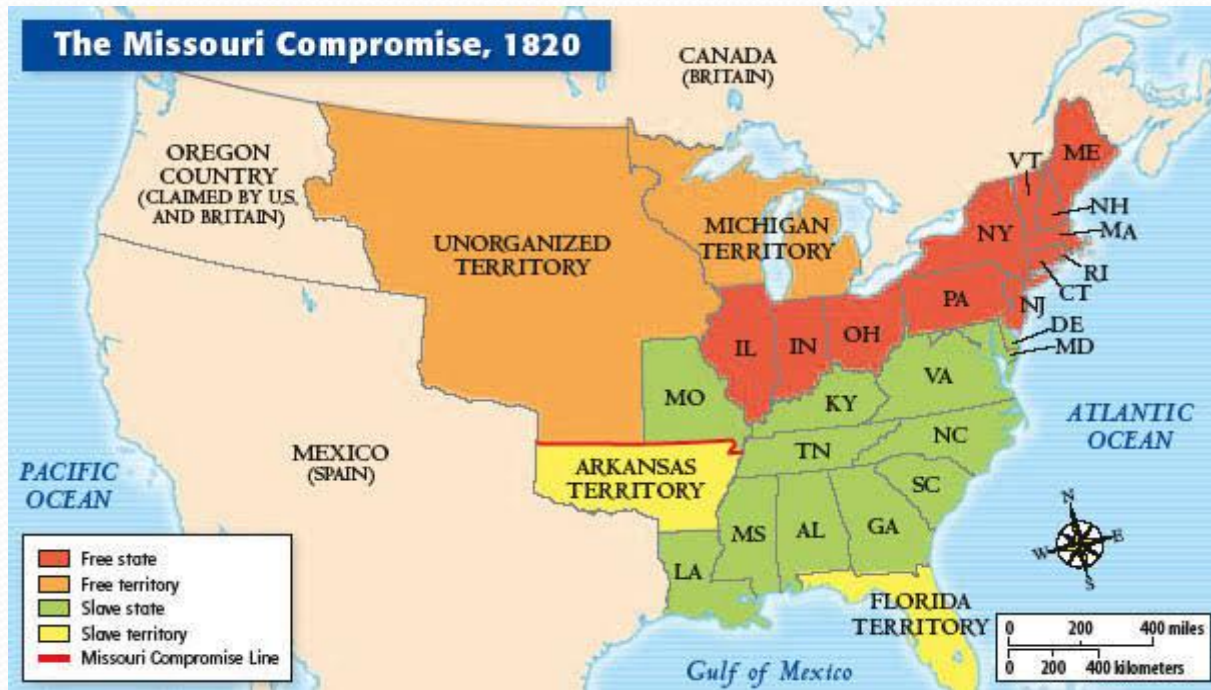

- In 1820, a bitter debate over the federal government's right to restrict slavery over Missouri's application for statehood ended in a compromise: Missouri was admitted to the Union as a slave state, Maine as a free state and all western territories north of Missouri's southern border were to be free soil

Leaders who fought to abolish slavery



- From the 1830s to the 1860s, the movement to abolish slavery in America gained strength, led by free Black people such as Frederick Douglass and white supporters such as William Lloyd Garrison, founder of the radical newspaper *The Liberator*, and Harriet Beecher Stowe, who published the bestselling antislavery novel *Uncle Tom's*

Sojourner Truth and Harriet Tubman were the two most prominent abolitionist



Sojourner Truth was an American abolitionist and women's rights activist. The truth was born into slavery in Swartekill, New York, but escaped with her infant

Occupation: Abolitionist, author, human rights

Died: November 26, 1883 (aged 86)

Born: Isabella Baumfree; c. 1797

Harriet Tubman was an escaped enslaved woman who became a "conductor" on the Underground Railroad, leading enslaved people to freedom before the Civil War, carrying a bounty on her

Parent(s): James Baumfree;

Elizabeth Baum

John Brown's efforts to overthrow slavery

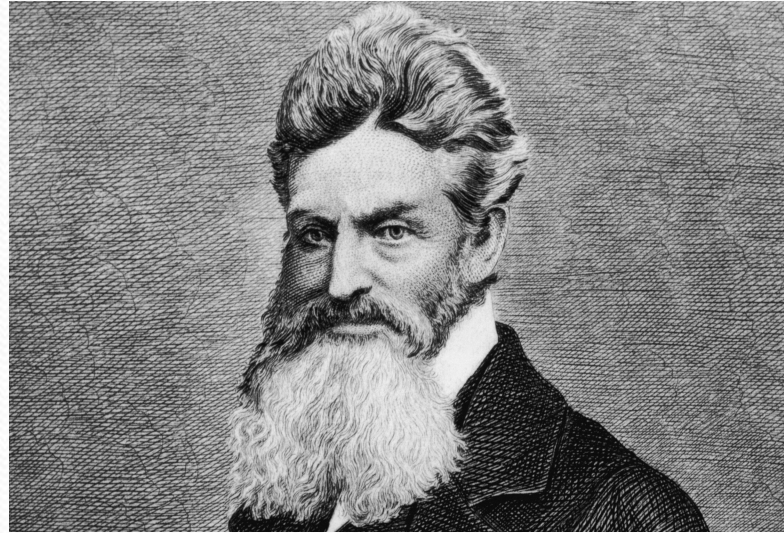

John Brown's raid on Harpers Ferry was an effort by abolitionist John Brown, from October 16 to 18, 1859, to initiate a slave revolt in Southern states by taking over the United States arsenal at Harpers Ferry

Some of the distrust of law enforcement in the black community goes back to slavery



- Slave catchers were viewed as the first policeman. They captured and abused runaway slaves.
- We must remember that today's police officers are our cousins, uncles, aunts, nieces, and nephews.
- We need to show respect for law enforcement. They are not slave catchers from the past.

Slave catchers were somewhat of a police force to track down escaped slaves

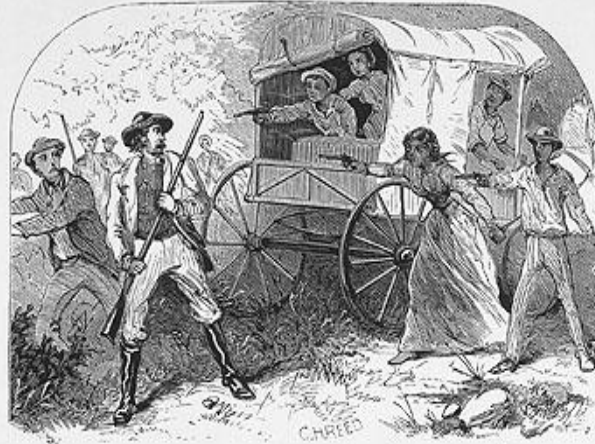

A BOLD STROKE FOR FREEDOM.

- **In the United States, a slave catcher was employed to track down and return enslaved people to their enslavers.**
- **The first slave catchers in the Americas were active in European colonies in the West Indies during the sixteenth**

The Dred Scott decision ruled that a black person could be arrested as an enslaved person if he moved from a Free State.



Dred Scott decision, formally *Dred Scott v. John F.A. Sandford*, was a legal case in which the U.S. Supreme Court, on March 6, 1857, ruled (7–2) that an enslaved person (Dred Scott) who had resided in a free state and territory (where slavery was prohibited) was not thereby entitled to his freedom in an in another state.

The civil rights actions of President Abraham Lincoln

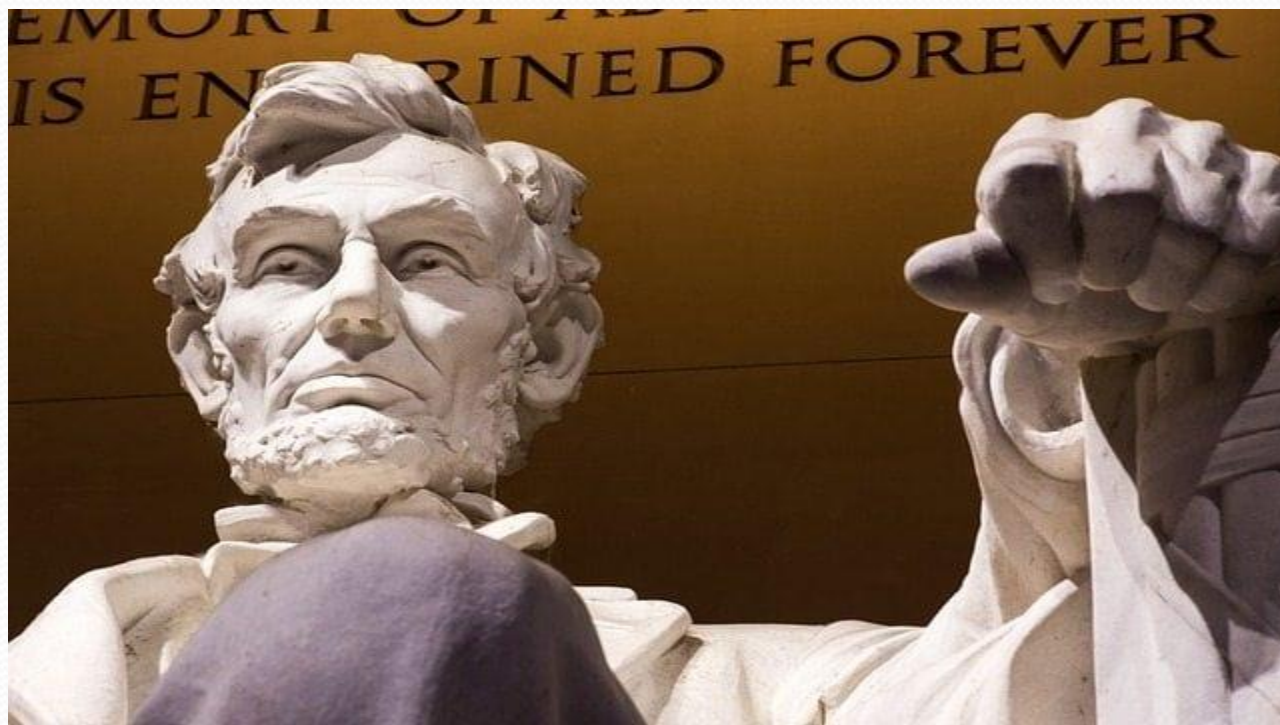

Abraham Lincoln, the president who freed the enslaved people

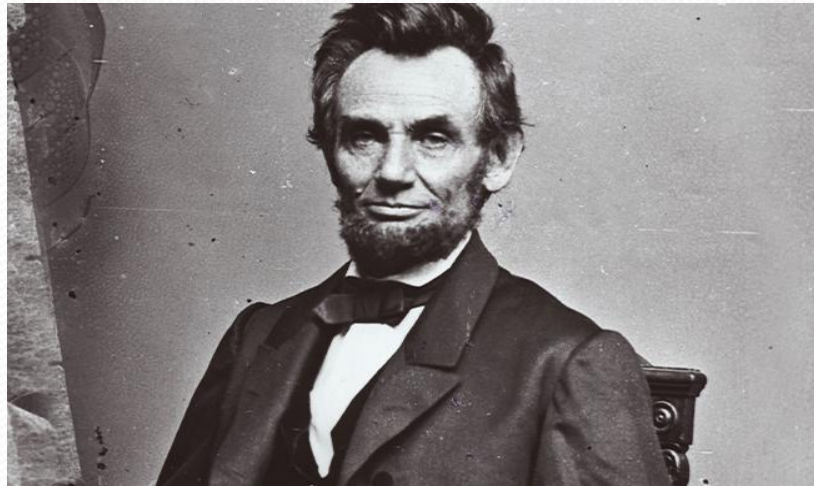

- Abraham Lincoln, a self-taught lawyer, legislator, and vocal opponent of slavery was elected 16th president of the United States in November 1860, shortly before the outbreak of the Civil War.
- Lincoln proved to be a shrewd military strategist and a savvy leader: His Emancipation Proclamation paved the way for slavery's abolition. At the same time, his Gettysburg

The war that freed the slaves



- American Civil War
- **Apr 12, 1861 -**
- **Description**
- **The American Civil War was a civil war in which the United States fought between the Union and the Confederacy.**
- **The main cause of the war was the status of slavery, especially the expansion of slavery into territories acquired as a result of the**

The Emancipation Proclamation

BY THE PRESIDENT OF THE UNITED STATES OF AMERICA.

A Proclamation.

Whereas, on the twenty-second day of September, in the year of our Lord one thousand eight hundred and sixty-two, a proclamation was issued by the President of the United States, containing, among other things, the following, to wit:

“That on the first day of January, in the year of our Lord one thousand eight hundred and sixty-three, all persons held as slaves within any State or designated part of a State, the people whereof shall then be in rebellion against the United States, shall be then, thenceforward, and forever, free; and the Executive government of the United States, including the military and naval authority thereof, will recognize and maintain the freedom of such persons, and will do no act or acts to repress such persons, or any of them, in any efforts they may make for their actual freedom.

- **President Abraham Lincoln issued the Emancipation Proclamation on January 1, 1863, as the nation approached its third year of bloody civil war.**

Juneteenth is a federal Holiday that commemorates the last black people who were finally freed

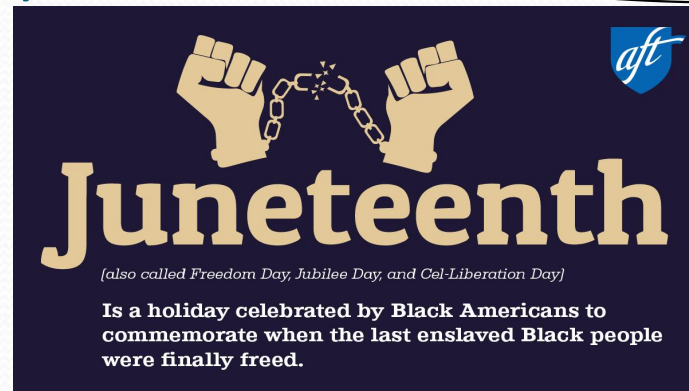

- **Juneteenth**^[c] (officially **Juneteenth National Independence Day** and also known as **Jubilee Day**,^[3] **Emancipation Day**,^{[4][5]} **Freedom Day**,^[6] and **Black Independence Day**^[6]) is a federal holiday in the United States commemorating the emancipation of enslaved African-Americans. It is also often observed to celebrate African-American culture.^[6] Originating in Galveston, Texas, celebrated annually on June 19 in various parts of the United States since 1865.
- The day was recognized as a federal holiday on June 17, 2021, when President Joe Biden signed the Juneteenth National Independence Day Act.^{[7][8]} Juneteenth's commemoration is on the June 19, 1865, announcement of General Order No. 3 by Union Army General Gordon Granger, proclaiming freedom for enslaved people in Texas,^[9] which was the last state of the Confederacy with institutional slavery.

13th amendment abolished slavery

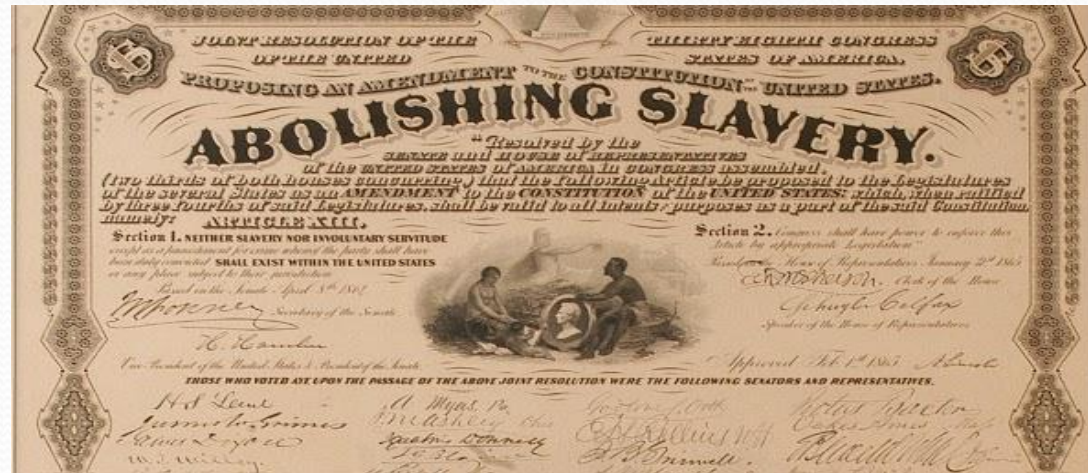

- **The Thirteenth Amendment to the United States Constitution abolished slavery and involuntary servitude, except as a punishment for a crime.**
- **The amendment was passed by Congress on January 31, 1865, ratified by the**

14th amendment granted citizenship

14th Amendment

...nor shall any state deprive any person of life, liberty, or property, without due process of law; nor deny to any person within its jurisdiction the equal protection of the laws.

- **Passed by the Senate on June 8, 1866, and ratified two years later, on July 9, 1868, the Fourteenth Amendment granted citizenship to all persons "born or naturalized in the United States," including formerly enslaved people. It**

15th amendment guaranteed African American men the right to vote

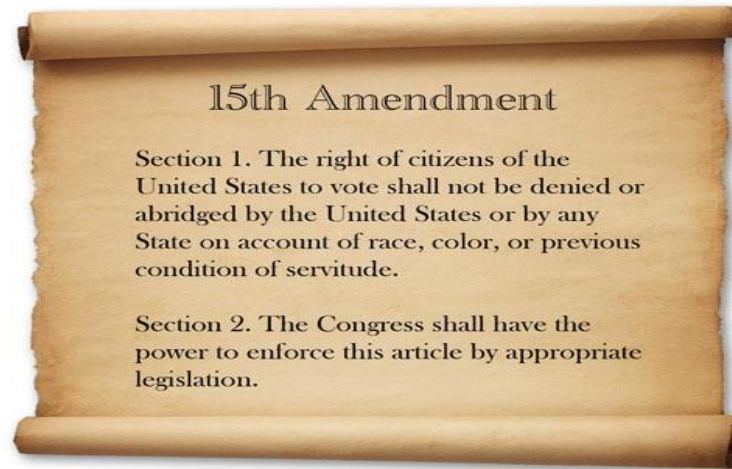

- **Passed by Congress February 26, 1869, and ratified February 3, 1870, the 15th amendment granted African American men the right to vote. ... Set free by the 13th amendment, with**

Southern Reconstruction

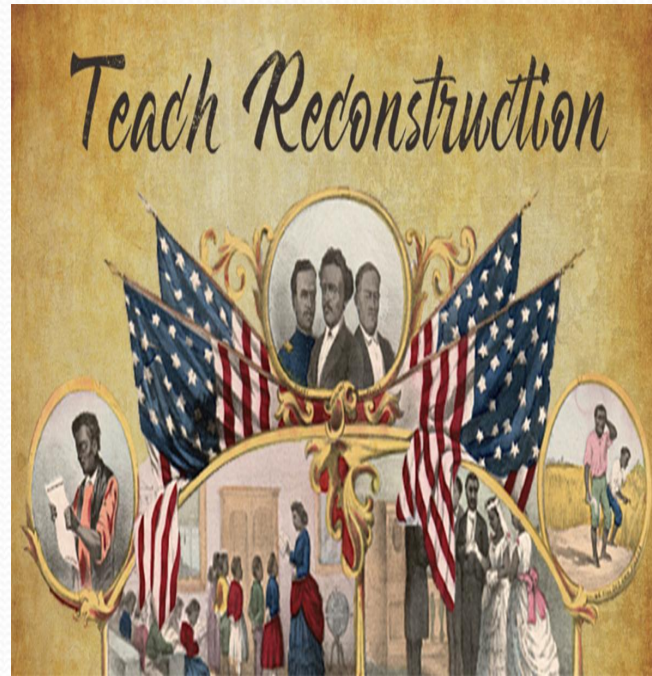

- **Reconstruction** refers to the period immediately after the Civil War from 1865 to 1877, when several United States administrations sought to reconstruct society in the former

The Freedmen's Bureau an agency that helped freed blacks

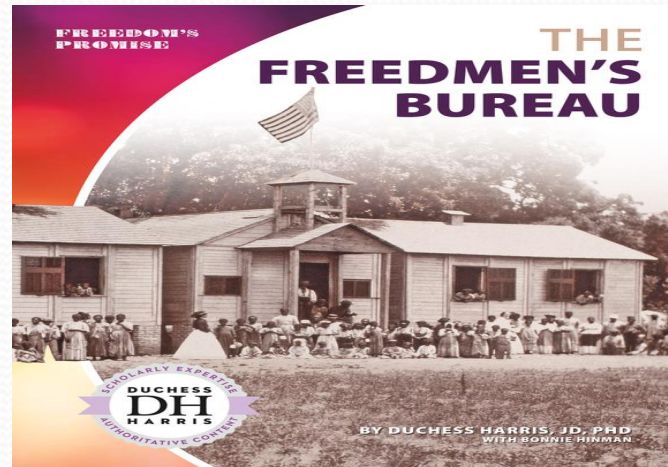

- The **Bureau of Refugees, Freedmen, and Abandoned Lands**, usually referred to as simply the **Freedmen's Bureau**,^[1] was an important agency of early Reconstruction, assisting freedmen in the South. It was established on March 3, 1865, and operated briefly as a U.S. government agency, from 1865 to 1872, after the American Civil War, to direct "provisions, clothing, and fuel...for the immediate and temporary shelter and supply of destitute and suffering refugees and freedmen and their wives and children".
- The Freeman's Bureau laid a foundation where blacks built elementary schools, high schools, and schools of higher education such as Shaw University, Hampton University, Tuskegee University, and many others. Employment, hospitals, and providing various services to the recently released enslaved people were also a part of the plan.

Racial discrimination became more intense when reconstruction and the Freedmen's Bureau ended.

Black Code Examples

- could not rent or lease farmland
- could not testify against whites
- could not start their own business
- could not carry a weapon
- could not serve on a jury
- could not marry a white

Precursor to Jim Crow Laws

- literacy test
- poll tax
- grandfather clause



THE JIM CROW LAWS

- Whites are superior to Blacks in all ways
- White and Blacks breeding would produce a mongrel race
- Violence is acceptable to keep Blacks in check
- A black male couldn't shake hands with a white male

REST ROOMS
WHITE COLORED

L&N

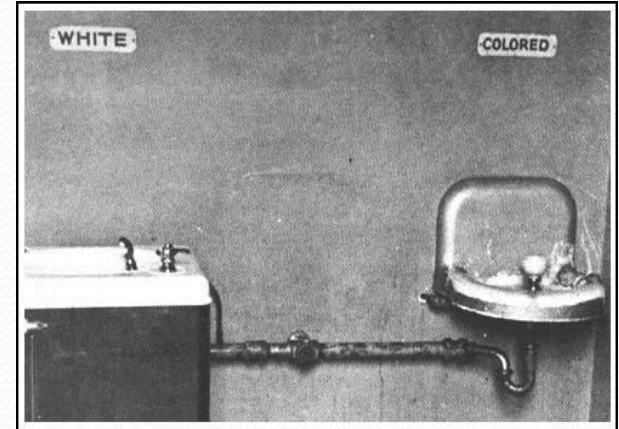

States instituted black code laws before the civil war. They later became known as Jim Crow laws. The laws were **restrictive laws designed to limit the freedom of African Americans** and ensure voting restrictions and cheap labor.

The Klan and White supremacy intimidation



The Freedmen's Bureau sponsored the building of elementary schools, high schools, colleges, and hospitals, which accelerated the progress of the newly released enslaved persons. But unfortunately, numerous hate groups organized to slow their progress.

The Ku Klux Klan was a roadblock to black generational wealth.



The Klan burned schools, churches, private homes, and businesses; the Klan also terrorized and lynched innocent blacks. Moreover, the intimidation of the Klan was a roadblock to black generational wealth.

The re-enslavement of blacks



Blacks were well on their way to building a political dynasty until discrimination set in



- The First Colored Senator and Representatives, Currier & Ives lithography, 1872. Left to right: **Senator Hiram Revels (MS)**, Representatives Benjamin Turner (AL), Robert DeLarge (SC), Josiah Walls (FL), Jefferson Long (GA), Joseph Rainey (SC), and Robert Elliott (SC).



Mississippi instituted a voter discrimination law that said that a voter had to have a Grandfather qualified to vote before 1865. The law eliminated black male voters. Other southern states instituted similar laws.



THE REASON.

NORTHERNER.—I understand that there was a light vote at the recent election.
COLORED ARKANSAN.—Yassah! Dat 's de troof, sah. De dark vote done reorganized de fact dat it was safest to stay at home.

Mississippi enacted a “grandfather clause” that permitted registering anyone whose grandfather was qualified to vote before the Civil War, which benefited only white citizens. The “grandfather clause” and the other legal barriers to black voter registration worked. Mississippi cut the percentage of black voting-age men registered to vote from more than 90 percent during Reconstruction to less than 6 percent in 1892. Other southern states adopted similar laws.

The Mississippi Grand Father Clause Law slowed black voting but did not eliminate it.

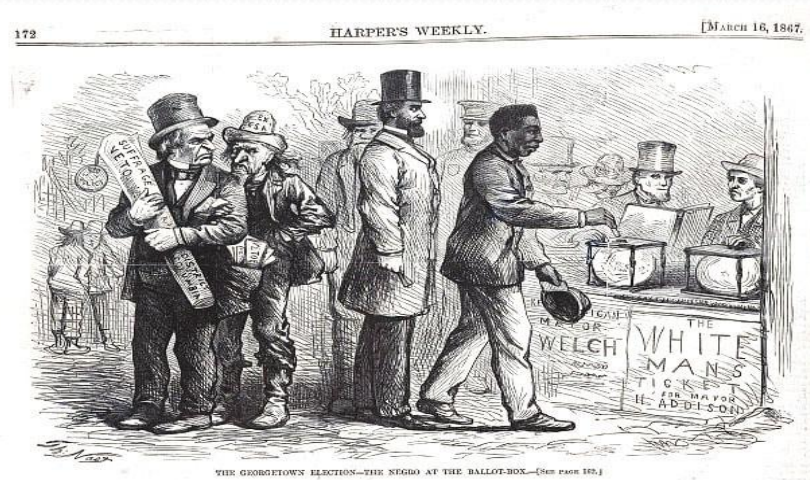

- As a result of intimidation, violence, and racial discrimination in state voting laws, a mere 3 percent of voting-age black men and women in the South were registered to vote in 1940. In Mississippi, less than 1 percent were registered. Most blacks who did vote lived in the larger cities of the South.

Hiram Revels of Mississippi became the first African American senator in 1870. He was born in North Carolina in 1827



Hiram Revels of Mississippi became the first African American senator in 1870. Born in North Carolina in 1827, Revels attended Knox College in Illinois and later served as a minister in the African Methodist Episcopal Church in Baltimore, Maryland. He raised two black regiments during the Civil War and fought at Vicksburg in Mississippi. The Mississippi state legislature sent him to fill a vacancy in the U.S. Senate during Reconstruction, and he quickly became an outspoken opponent of racial segregation. Although Revels' term in the Senate lasted just a year, he broke new ground for African Americans in Congress.

Blanche K Bruce was the second black male elected to the Senate.



Born into slavery in 1841, Blanche K. Bruce (R-MS) spent his childhood years in Virginia, where he received his earliest education from the tutor hired to teach his master's son. At the dawn of the Civil War, Bruce escaped slavery and traveled north to begin a distinguished career in education and politics. Elected to the Senate in 1874 by the Mississippi state legislature, he served from 1875 to 1881. In 2002 the Senate commissioned a new portrait of Bruce, now on display in the U.S. Capitol. *(Photo: Library of Congress)*

Edward Brooks was the first black senator elected in the modern era more than 86 years after reconstruction (discriminatory Jim Crow laws did their job)



The first African American elected to the Senate by popular vote, **Edward Brooke** (R-MA), served two full terms from 1967 to 1979. In 1919, Brooke graduated from Howard University in Washington, D.C., before serving in the United States Army during World War II. After the war, he received his Juris Doctor degree from Boston University. During his Senate career, he championed the causes of low-income housing and an increased minimum wage and promoted commuter rail and mass transit systems. He also worked tirelessly to promote racial equality in the South. *(Photo: Senate Historical Office)*



Major roadblocks prevented blacks from acquiring political capital following reconstruction until primary civil rights legislation during the 1960s



- Black code laws
- Jim Crow laws
- Poll tax laws
- Land-owner the law
- Poll question laws
- Grandfather clause laws
- Voter intimidation
- Lynching burnings and physical attacks

- All of the preceding factors decreased the black vote after reconstruction

Significant events that slowed black political and economic power



- Plessy versus Ferguson Supreme Court decision
- Segregation
- Widespread lynching
- Tulsa black Main St bombing
- The 1898 Wilmington NC riots
- Discrimination in the Homestead act
- Redlining housing and loan discrimination

Plessy versus Ferguson was a landmark 1896 US Supreme Court decision that instituted legal discrimination to be separate and equal.

Plessy v. Ferguson

Supreme
Court
Briefs



- *Plessy v. Ferguson* was a landmark 1896 U.S. Supreme Court decision that upheld the constitutionality of racial segregation under the “separate but equal” doctrine. The case stemmed from an 1892 incident in which an African American male refused to sit in the section reserved for blacks on a train. In the case of Homer Plessy, the plaintiff was seven-eighths white and one-eighth black and had the appearance of a white man. On June 7, 1892, he purchased a first-class ticket for a trip between New Orleans and Covington, La., and took a vacant seat in a white-only car. His arrest followed the case was appealed to the Supreme Court.
- The court ruled in favor of separate but equal accommodations for blacks and whites: separate restrooms, drinking fountains, entertainment facilities, and living areas became law. However, the services were not similar. The ruling ushered in legal segregation throughout America.

The Plessy versus Ferguson case did not bring about equal opportunities nor equal accommodations

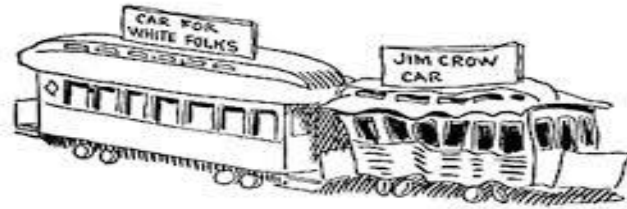

1904 political cartoon of "White" and "Jim Crow" rail cars by John T. McCutcheon. Despite Jim Crow's legal pretense that the races be "separate but equal" under the law, non-whites were given inferior facilities and treatment.

- Public services were not equal. Blacks usually had to go to the back entrance to receive food in brown paper bags. People of color were not allowed to attend various entertainment events and were banned from playing in the Major leagues and the National Football League.
- Many black students in the South used outdated books handed down from white school systems. There was no oversight to enforce the Plessy versus Ferguson mandate of separate but equal accommodations. The lack of black political representation made it challenging to implement the directive fairly and equitably.

Brown versus the Board of Education Led to legally overturning segregation which took years to enforce

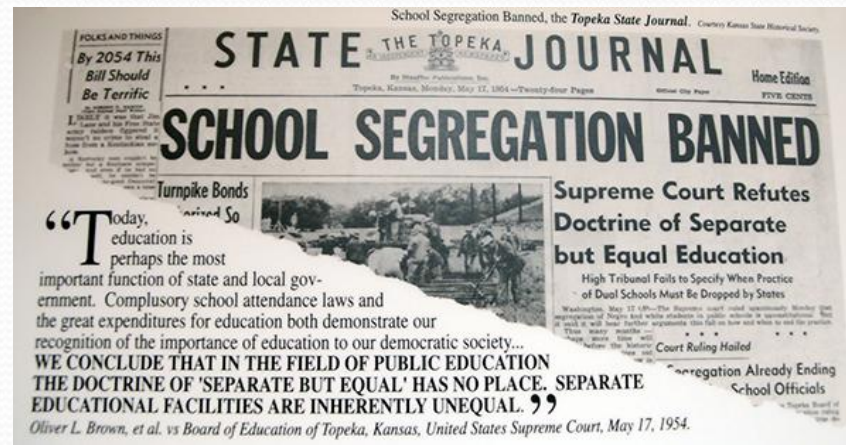

- **Brown v. Board of Education of Topeka, Kansas second (1954), was a landmark decision of the U.S. Supreme Court. The Court ruled that U.S. state laws establishing racial segregation in public schools are unconstitutional, even if the segregated schools are otherwise equal.**

Lawyers behind the board the Brown versus the Board of Education decision



- **Thurgood Marshall** was the lead lawyer. His associates' lawyers were James Nabrit Jr. bright, and EC Hayes. Thurgood Marshall was the first black Supreme Court Justice. October 1967 until October 1991. President Lyndon Baines Johnson appointed him to the court; he was a champion of civil rights.
- **Charles Hamilton Houston** (September 3, 1895 – April 22, 1950) was a prominent African-American lawyer, Dean of Howard University Law School, and NAACP's first special counsel or Litigation Director. A graduate of Amherst College and Harvard Law School, Houston played a significant role in dismantling Jim Crow laws, especially attacking segregation in schools and racial housing covenants. He earned the title "The Man Who Killed Jim Crow."^[2]
- Houston is also well known for having trained and mentored a generation of black attorneys, including Thurgood Marshall, future founder and director of the NAACP Legal Defense Fund and the first Black Supreme Court Justice.^[3] He recruited young lawyers to work on the NAACP's litigation campaigns, building connections between Howard's and Harvard's university law schools.

Continued barriers to building black generational wealth

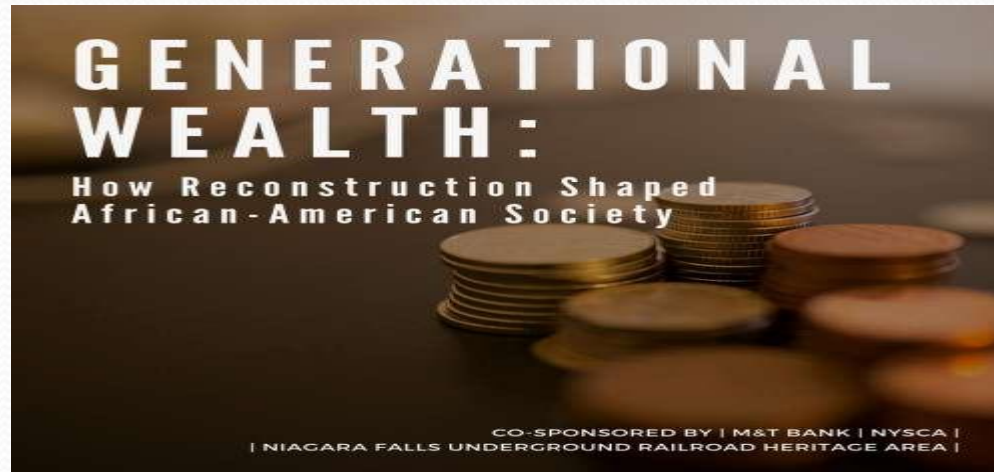

- Widespread lynching
- Discrimination in the Homestead act
- The Wilmington massacre of 1898
- Tulsa black Wall Street bombing
- Redlining

Widespread lynching



- Lynching in the United States was the widespread occurrence of extrajudicial killings, which began in the pre–Civil War South in the 1830s. It ended during the civil rights movement in the 1950s and 1960s. Although the victims of lynching were of various ethnicities, after roughly 4 million enslaved African Americans were emancipated, Southerners targeted African Americans. Lynching's in the U.S. reached its height from the 1890s to the 1920s, and it primarily victimized ethnic minorities. Most of the lynchings occurred in the American South because most African Americans lived there, but racially motivated lynchings also occurred in the Midwest and border states.^[2]
- Blacks in the South had very little protection under the law. As a result, they were often scapegoats for crimes committed by whites. Black males were particularly singled out for lynchings when there was a crime. Lynchings were public spectacles that drew large crowds that some found entertaining.

Discrimination in the Homestead act

DEFINITION

Homestead Act

law passed by Congress in 1862 that granted 160 acres of federal land to any U.S. citizen

©Study.com

- The **Homestead Acts** were several laws in the United States by which an applicant could acquire re ownership of government land or the public domain, typically called a homestead. More than 160 million acres (650 thousand km²; 250 thousand sq mi) of public land, or nearly 10 percent of the total area of the United States, was given away free to 1.6 million homesteaders; most of the homesteads were west of the Mississippi River.
- The 1866 Act explicitly included black Americans and encouraged them to participate, but rampant discrimination, systemic barriers, and bureaucratic inertia slowed black gains. Black had a tough time is acquiring homestead land. Unfair treatment was a significant roadblock to building wealth within the black community.

The Wilmington massacre of 1898

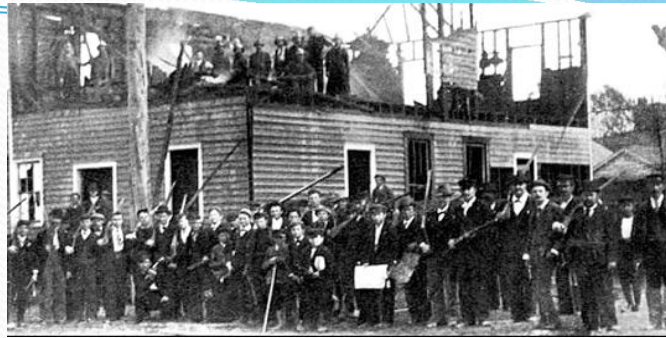

- The **Wilmington insurrection of 1898**, also known as the **Wilmington massacre of 1898** or the **Wilmington coup of 1898**,^[6] was a riot and insurrection carried out by white supremacists in Wilmington, North Carolina, United States, on Thursday, November 10, 1898.^[7] The white press in Wilmington originally described the event as a race riot caused by black people, as the white press typically did when faced with news of race massacres. Since the late 20th century and further study, the insurrection has been characterized as a *coup d'état*, the violent overthrow of a duly elected government by white supremacists.
- The Wilmington insurrection of 1898, more than any other, was a direct attack on black political and business progress. Blacks were in control of law enforcement and had an influential newspaper. Blacks owned most of the companies, including 13 of the 14 restaurants. Some 2000 white supremacists came from other states and attacked the city. It was a coup de ta the overthrow of a legitimate government. The North Carolina Governor did not intervene.
- The Black Middle and Upper Class were displaced or run out of town. Their homes were confiscated. There's no official count of how many blacks lost their lives, but it was substantial. The insurrection was a significant setback in building black generational wealth. The city was majority black at the time.

Tulsa black Wall Street bombing



- The **Tulsa race massacre** took place on May 31 and June 1, 1921, when mobs of white residents, some of whom had been deputized and given weapons by city officials,^[12] attacked Black residents and destroyed homes and businesses of the Greenwood District in Tulsa, Oklahoma, US. Alternatively known as the **Tulsa pogrom**,^[13] the **Tulsa race riot**^[14] or the **Black Wall Street massacre**,^[15] the event is considered one of "the single worst incident[s] of racial violence in American history."^[16] The attackers burned and destroyed more than 35 square blocks of the neighborhood – at the time, one of the wealthiest Black communities in the United States, known as "Black Wall Street."^[17]
- The Tulsa race massacre put a dent in black generational wealth. Words cannot describe the devastation where over 800 people were injured and 38 people lost their lives. Attackers burned and destroyed more than 35 square acres of the neighborhood, and as mentioned, it was the wealthiest black community in the United States. Where would the community be; if the riot had not occurred, that is a question that needs attention.

Redlining



- Redlining is a discriminatory practice that puts services (financial and otherwise) out of reach for specific areas based on race or ethnicity. It can be seen in the systematic denial of mortgages, insurance, loans, and other financial services based on location (and that area's default history) rather than on an individual's qualifications and creditworthiness. Notably, the policy of redlining is felt the most by residents of minority neighborhoods.
- Redlining was common in both the North and the South; it denied loans for businesses, kept neighborhoods segregated, and denied insurance and mortgages. Redlining set up major roadblocks to generational wealth in the black community. It is still a common practice today in certain areas.

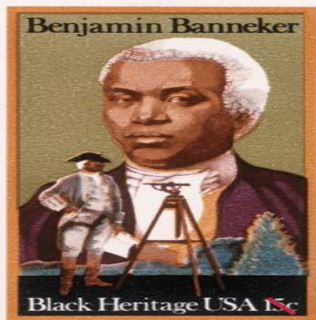

Benjamin Banneker

Born: Nov. 9, 1731, Ellicott's Mills, Md.

Died: Oct. 25, 1806, Baltimore, Md., U.S.

- mathematician
- astronomer
- compiler of almanacs
- inventor and writer
- one of the first influential Black American intellectuals.
- **Benjamin was one of the most intellectual African Americans best known for his astronomical**



Crispus Attucks

Born: 1723?

Died: March 5, 1770, Boston, Mass. [U.S.]

The first American killed in the Boston Massacre which led to the American Independence War



Phillis Wheatley,

Born: 1753, in present-day Senegal?, West Africa

Died: December 5, 1784, Boston, Massachusetts, U.S.

- Mastered English
- Learned Greek and Latin
- At the age of 14, wrote mature poetry dealing with piety and morality



Sojourner Truth

Born: 1797, in Ulster county, N.Y., U.S.

Died: Nov. 26, 1883, in Battle Creek, Mich.

- evangelist
- reformer
- abolitionist and women's rights movements supporter

Harriet
Tubman

They called
her Moses



Harriet Tubman

Born: 1820, in Dorchester county, Maryland, U.S.

Died: March 10, 1913, Auburn, New York

- escaped from slavery in the South to become a leading abolitionist before the American Civil War
- led hundreds of bondsmen to freedom in the North along the Underground Railroad route—an elaborate secret network of safe houses organized for that purpose.

The Underground Railroad was a network of secret routes and safe homes for escaped slaves

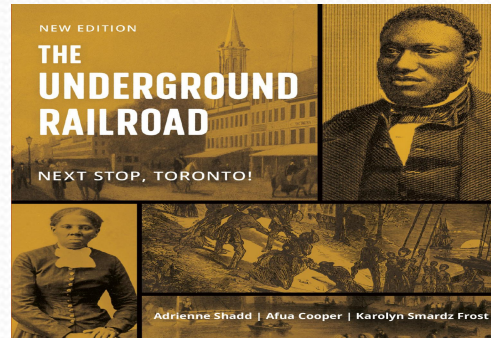

- The **Underground Railroad** was a network of secret routes and **safe houses** established in the United States during the early- to the mid-19th century. Enslaved African Americans used it primarily to escape **free states** and Canada.^[1] The network was assisted by **abolitionists** and others sympathetic to the cause of the **escapees**.^[2]
- The enslaved who risked escape and those who aided them are also collectively referred to as the "Underground Railroad."^[3] Various other routes led to Mexico,^[4] where slavery had been abolished, and to islands in the **Caribbean** that were not part of the slave trade.^[5] An earlier escape route running south toward **Florida**, then a **Spanish** possession (except 1763–83), existed from the late 17th century until approximately 1790.^{[6][7]} However, the network now generally known as the Underground Railroad began in the late 18th century. It ran north and grew steadily until President Abraham Lincoln signed the Emancipation Proclamation.^[8] One estimate suggests that by 1850, approximately 100,000 enslaved people had escaped via the network.^[8]

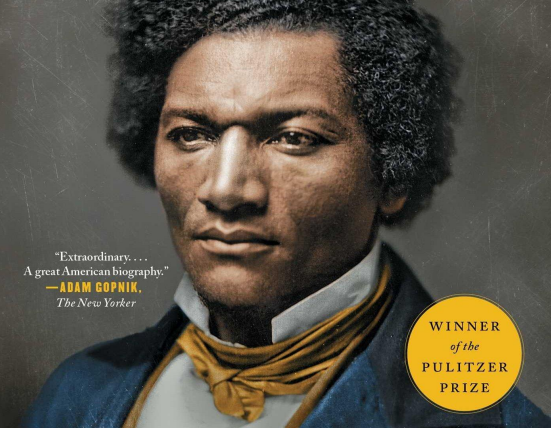

Frederick Douglass

Born: February 1818?, Tuckahoe, Maryland, U.S.

Died: February 20, 1895, Washington, D.C.

- one of the most eminent human-rights leaders of the 19th century.
- his oratorical and literary brilliance thrust him into the forefront of the U.S. abolition movement
- became the first black citizen to hold a high-ranking position in the U.S. government.

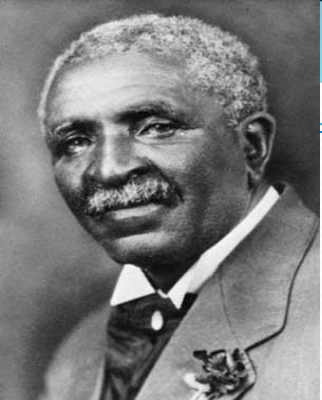

George Washington Carver

Born: 1862 near Diamond Grove, Mo., U.S.

Died: Jan. 5, 1943, Tuskegee, Ala.

- agricultural chemist, agronomist, and experimenter
- developed new products derived from peanuts (groundnuts), sweet potatoes, and soybeans
- revolutionize the agricultural economy of the South
- taught and conducted research at the Tuskegee Normal and Industrial Institute (now Tuskegee University) in Tuskegee, Ala.



Booker T. Washington

Born: April 5, 1856, Franklin County, Va., U.S.

Died: Nov. 14, 1915, Tuskegee, Ala.

- educator
- reformer,
- first president and principal developer of Tuskegee Normal and Industrial Institute (now Tuskegee University),
- the most influential spokesman for black Americans between 1895 and 1915.
- Wrote a book titled “Up from Slavery.”

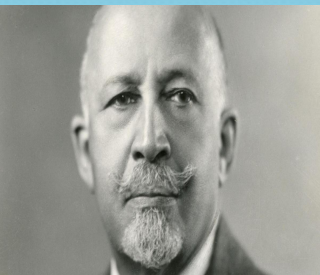

W. E. B. Du Bois

Born: February 23, 1868, Great Barrington,
Massachusetts, U.S.

Died: August 27, 1963, Accra, Ghana

- American sociologist
- The most influential black protest leader in the United States during the 20th century.
- shared in the creation of the National Association for the Advancement of Colored People (NAACP) in 1909 and
- Edited *the Crisis* magazine from 1910 to 1934. The primary NAACP publication
- Wrote a book titled “The Souls of Black Folk.”



Matthew Alexander Henson

(Born: August 8, 1866 Died: March 9, 1955)

- American explorer
- long-time companion to Robert Peary; a famous white explorer
- He, along with Peary, was the first to reach the North Pole in 1909.
- did not achieve contemporary recognition in an America because of racism



Jack Johnson

Born: March 31, 1878, Galveston, Texas, U.S.

Died: June 10, 1946, Raleigh, N.C.

- Johnson fought professionally from 1897 to 1928 and engaged in exhibition matches as late as 1945. He
- won the title by knocking out champion Tommy Burns in Sydney on Dec. 26, 1908, and lost it on a knockout by Jess Willard in 26 rounds in Havana, April 5, 1915.
- First black heavyweight champion



Madam C. J. Walker (1867–1919) invented a hair-growing lotion.

Fast Fact: Walker grew up poor. But she became the first female African- American millionaire.

- businesswoman and philanthropists generally acknowledged being the first black female millionaire in the United States
- worked as a washerwoman and began experimenting at home with various hairdressings
- in 1905, she developed a formula for creating a smooth, shiny hairstyle for African American women



Mary McLeod Bethune

Born: July 10, 1875, Mayesville, S.C., U.S.

Died: May 18, 1955, Daytona Beach, Fla.

- educator who was active nationally in African American affairs and
- was a special adviser to President Franklin D. Roosevelt on the problems of minority groups
- started Bethune Cookman College in 1943

to attend and graduate from MIT



Robert Robinson Taylor was an American architect and educator. Taylor was the first African-American student enrolled at the Massachusetts Institute of Technology and the first accredited African-



Benjamin O. Davis, Sr.

Born: July 1, 1877, Washington, D.C., U.S.

Died: November 26, 1970, North Chicago, Ill.

- rose slowly through the ranks, becoming the first black colonel in the army in 1930.
- in 1940, he was promoted to brigadier general by President Franklin D. Roosevelt. After commanding the 2nd Cavalry Division in 1941



James Weldon Johnson

Born: June 17, 1871, Jacksonville, Fla., U.S.

Died: June 26, 1938, Wiscasset, Maine

- composer wrote the song “Lift Every Voice and Sing,” based on James's 1900 poem of the same name, which became a national anthem to many African-Americans.
- wrote over 200 songs.
- wrote the play God's Trombones
- Field organizer for the (NAACP) from 1917 to 1920 increased (NAACP) regional branches from 68 to 310





Carter G. Woodson

Born: Carter Godwin Wilson, December 9, 1875, in New Canton, Buckingham County, VA; Died: April 4, 1950, in Washington, DC

- known today as "the father of black history" and is credited with laying the foundations for the widespread adoption of black studies in American schools.
- founded the Association for the Study of Negro Life, and professional historians largely ignored History in 1915, the achievements of blacks.
- earned a Ph.D. in history from Harvard in 1912
- In February of 1926, he launched Negro History Week.





Bessie Coleman

Born: Jan. 26, 1893, Atlanta, Texas, U.S.

Died: April 30, 1926, Jacksonville, Fla.

- staged the first public flight by an African American woman in America on Labor Day, September 3, 1922
- became a famous flier at aerial shows, though she refused to perform before segregated audiences in the South





Langston Hughes

Born: Feb. 1, 1902, Joplin, Missouri, U.S.
Died: May 22, 1967, New York, New York

- black poet and writer
- wrote about the black experience in America
- was fluent in French and Spanish
- was one of the most prolific writer of his era





Marian Anderson

Born: February 27, 1897, Philadelphia, Pa., U.S.

Died: April 8, 1993, Portland, Ore.

- In 1939, she was denied an opportunity to sing at Washington, D.C.'s Constitution Hall, owned by the Daughters of the American Revolution.
- refused because of her race.
- It sparked widespread protest from many people, including Eleanor Roosevelt, who, along with many other prominent women, resigned from the DAR.
- Arrangements were made for Anderson to appear instead at the Lincoln Memorial on Easter Sunday, and she drew an audience of 75,000.





Charles Hamilton Houston

(Born: September 3 1895–
Died: April 22 1950)

- Physician, scientist, and Peace Corps worker
- Civil rights lawyer and educator
- Dean of Howard University
- Teacher and advisor to Thurgood Marshall
- Was the mind behind the modern Civil Rights movement called the Moses of the movement



James Baldwin famous writer and civil rights activist



- **James Arthur Baldwin** (August 2, 1924 – December 1, 1987) was an American **writer** and **activist**. He garnered acclaim across various mediums, including **essays**, **novels**, **plays**, and **poems**.
- His first novel, *Tell It On The Mountain*, was published in 1953; decades later, *Time Magazine* included the novel on its list of the **100 best English-language novels released from 1923 to 2005**.^[1] His first essay collection, *Notes of a Native Son*, was published in 1955.^[2]

Maya Angelou famous writer, poet, civil rights activist



- Maya Angelou, born Marguerite Ann Johnson on April 4, 1928, in St. Louis, Missouri, was an American poet, memoirist, actress, and an important figure in the American Civil Rights Movement. In 2001 she was named one of the 30 most powerful women in America by Ladies Home Journal.
- Maya Angelou is known for her six autobiographies, starting with *I Know Why the Caged Bird Sings* (1969), which was nominated for a National Book Award and called her magnum opus. Her volume of poetry, *Give Me a Cool Drink of Water 'Fore I Die* (1971), was nominated for the Pulitzer Prize. ...more



Joseph Louis Barrow , also called the Brown Bomber

Born: May 13, 1914, Lafayette, Alabama, U.S.

Died: April 12, 1981, Las Vegas, Nevada

- a boxer who was world heavyweight champion from June 22, 1937, when he knocked out James J. Braddock in eight rounds in Chicago, until March 1, 1949,
- a bigger than life figure who inspired Black America during the Pre-Civil Rights era like no other leader



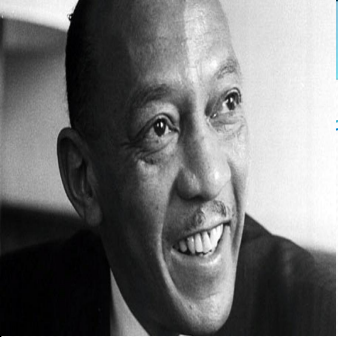

Jesse Owens

Born : September 12, 1913, Oakville, Alabama, U.S.

Died: March 31, 1980, Phoenix, Arizona

- track-and-field athlete
- set a world record in the running broad jump (also called long jump) that stood for 25 years
- won four gold medals at the 1936 Olympic Games in Berlin
- His four Olympic victories were a blow to Adolf Hitler's attempt to use the Games to demonstrate Aryan superiority.
- became a famous motivational speaker





Paul Robeson

born April 9, 1898, Princeton, N.J., U.S.

died Jan. 23, 1976, Philadelphia, Pa.

- The son of a former slave turned preacher, Robeson attended Rutgers University in New Brunswick, N.J.
- celebrated American singer, actor, and black activist.
- All American basketball, football, track, and baseball player
- Phi Beta Kappa
- Rutgers University Valedictorian





Jackie Robinson

Born: January 31, 1919, Cairo, Georgia, U.S.

Died: October 24, 1972, Stamford, Connecticut

- The first black baseball player to play in major American leagues during the 20th century.
- On April 15, 1947, Robinson broke the decades-old color bar of Major League Baseball when he appeared on the field for the National League Brooklyn Dodgers.
- Played as an infielder and outfielder for the Dodgers from 1947 through 1956.



The Tuskegee airmen faced racial discrimination when they return home



- In January 1941, the War Department formed the all-black **99th Pursuit Squadron** of the U.S. Army Air Corps (later the U.S. Army Air Forces) to be trained using single-engine planes at the segregated Tuskegee Army Airfield at **Tuskegee**, Alabama. The **National Association for the Advancement of Colored People** (NAACP), the black press, and others had been lobbying hard for the government to allow African Americans to become military pilots. Altogether, 992 pilots graduated from the Tuskegee Airfield courses, and they flew 1,578 missions and 15,533 sorties, destroyed 261 enemy aircraft, and won more than 850 medals.
- America did not honor the Tuskegee airmen when they returned home. They returned to racial discrimination and separation and were denied the GI bill.



Ralph Johnson Bunche

Born: Aug. 7, 1904, Detroit, Mich., U.S.

Died: Dec. 9, 1971, New York, N.Y.

- U.S. diplomat, a vital member of the United Nations for more than two decades
- Winner of the 1950 Nobel Prize for Peace for his successful negotiation of an Arab-Israeli truce in Palestine.
- Valedictorian of the 1927 UCLA class
- Earned a Ph.D. from Harvard



Rosa Parks

Born: February 4, 1913, Tuskegee, Alabama, U.S.

Died: October 24, 2005, Detroit, Michigan

- civil rights activist whose refusal to relinquish her seat on a public bus to a white man
- participated in the 1955–56 Montgomery bus boycott in Alabama, which was the spark that ignited the U.S. civil rights movement.
- called the mother of the Civil Rights Movement

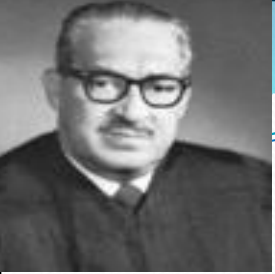

First black Supreme Court Justice

Thurgood Marshall

Born: July 2, 1908, Baltimore, Maryland, U.S.

Died: January 24, 1993, Bethesda

- lawyer, civil rights activist, and
- associate justice of the Supreme Court of the United States (1967–91)
- first African American member of the Supreme Court. As an attorney
- successfully argued before the U.S. Supreme Court the case of *Brown v. Board of Education of Topeka* (1954), which declared unconstitutional racial segregation in American public schools



Dr. Martin Luther King, Jr.

Born: January 15, 1929, Atlanta, Georgia, U.S.

Died: April 4, 1968, Memphis, Tennessee

- Baptist minister and social activist who led the civil rights movement in the United States from the mid-1950s until his death by assassination in 1968.
- His leadership was fundamental to the movement's success in ending the legal segregation of African Americans in the South and other parts of the United States.
- rose to national prominence through the organization of the Southern Christian Leadership Conference, which promoted nonviolent tactics and was a sponsor of the 1963 March in Washington) He was awarded the Nobel Prize for Peace in 1964.
- **Famous quote: "I dream that my four little children will one day live in a nation where they will not be judged by the color of their skin but by the content of their character."**



Malcolm X original name **Malcolm Little** ,

Born: May 19, 1925, Omaha, Nebraska, U.S.

Died: February 21, 1965, New York, New York

- Prominent figure in the Nation of Islam, who articulated concepts of race pride and black nationalism
- After his assassination, the widespread distribution of his life story—*The Autobiography of Malcolm X* (1965)—made him an ideological hero, especially among black youth.
- Famous statement: Education is an essential element in the struggle for Human Rights. It is the means to help our children and people rediscover their identity and thereby increase their self-respect.
- Famous quote “ education is our passport to the future, for tomorrow belongs to the people who prepare for it today.”

Alex Haley known for his book *Roots* and the television series *The Saga of an American Family*



- **Alexander Murray Palmer Haley** (August 11, 1921 – February 10, 1992)^[1] was an American writer and the author of the 1976 book *Roots: The Saga of an American Family*. ABC adapted the book as a television miniseries of the same name and aired it in 1977 to 130 million viewers. In the United States, the book and miniseries raised public awareness of black American history and inspired a broad interest in genealogy and family history.^[3]
- Haley's first book was *The Autobiography of Malcolm X*, published in 1965, collaborating through numerous lengthy interviews with Malcolm X.^{[4][5][6]}



Muhammad Ali original name **Cassius Marcellus Clay, Jr.**

Born: Jan. 17, 1942, Louisville, Ky., U.S.

- Professional boxer and social activist.
- The first fighter to win the world heavyweight championship on three separate occasions; he successfully defended this title 19 times. Ali is considered the most popular sports athlete of all time.

Soul singer James Brown coined the phrase "Say it loud I'm black and I'm proud"



The great soul singer James Brown said his song, Say it loud. I'm black, and I'm Proud, was a love song between him and black America. The song inspired many blacks to take pride in their heritage. As a result, large numbers of blacks begin to grow afros and wear African clothing to highlight their newfound pride and the love of their culture.

Hidden NASA engineer computer scientists and mathematicians that blacks should've known about 50 years ago. Learning their history and accomplishments would have been an inspiration to a generation of black Americans.



Mary Jackson a successful NASA engineer



- Mary Jackson worked in the all-black West Area Computing section, which monitored wind tunnels and flight experiments. Her job was to extract the relevant data from flight tests.
- Mary Jackson was a successful NASA engineer and advocate for women and minorities. (Image credit: NASA/LRC).

Katherine Johnson a brilliant NASA mathematician



Katherine Johnson did trajectory analysis for Alan Shepard's mission in 1961 and John Glenn's in 1962. (Image credit: NASA) For example, some of her math equations were used in a lecture series compendium called *Notes on Space Technology*. These lectures were given by engineers that later formed the Space Task Group, NACA's section on space travel.

Dorothy Vaughn a brilliant NASA computer scientist



- Vaughn was an expert programmer in FORTRAN, a prominent computer language of her day.
- Dorothy Vaughn became the first black supervisor at the National Advisory Committee for Aeronautics (NACA), a precursor of NASA, in 1949. (Image credit: NASA)

Charles Bolden the first black administrator of NASA

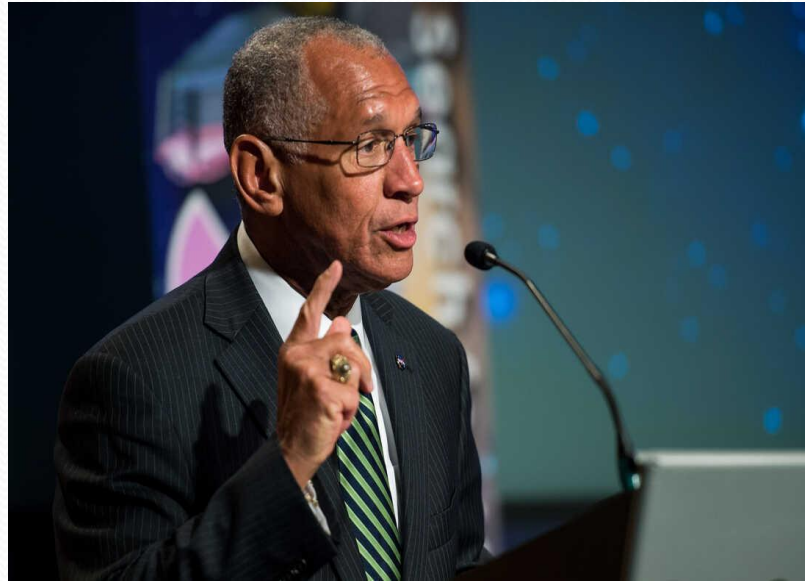

Bolden was not commissioned into the Naval Academy. He served in the Marine Corps as an aviator, flying more than 100 combat missions in North and South Vietnam, Laos, and Cambodia in the early 1970s. Bolden later became a NASA astronaut and traveled to orbit four times aboard the space shuttle. After his last space flight, he returned to the Marine Corps and achieved the rank of major general. Then in 2009, he was appointed the administrator of NASA, the first African-American to hold the office.



John Hope Franklin

Born: Jan. 2, 1915, Rentiesville, Okla., U.S.

- Historian and educator noted his scholarly reappraisal of the American Civil War era and the importance of the black struggle in shaping modern American identity.
- Long time professor of History at Duke University
- Helped fashion the legal brief that led to the historic Supreme Court decision outlawing public school segregation, *Brown v. Board of Education of Topeka* (1954), and was instrumental in developing African-American Studies programs at colleges and universities.

Shirley Chisholm was the first black person to run for president of the United States



- **Shirley Anita Chisholm** (November 30, 1924 – January 1, 2005) was an American politician, educator, and author.^[1] In 1968, she became the first black woman elected to the United States Congress.^[2] Chisholm represented New York's 12th congressional district, centered on Bedford–Stuyvesant,^[a] for seven terms from 1969 to 1983. In 1972, she became the first black candidate for a major-party nomination for President of the United States and the first woman to run for the Democratic Party's nomination.



Made a presidential run in 1983–84 and 1987–88 captured 6.9 million votes won seven primaries and four caucuses

Reverend Jesse Jackson

Born: October 8, 1941, Greenville, South Carolina

- civil rights leader, Baptist minister,
- politician whose bids for the U.S. presidency (in the Democratic Party's nomination races in 1983–84 and 1987–88) were the most successful by an African American. His life and career have been marked by both accomplishment and controversy.
- Jackson captured 6.9 million votes and won 11 contests: seven primaries (Alabama, the District of Columbia, Georgia, Louisiana, Mississippi, Puerto Rico, and Virginia) and four caucuses (Delaware, Michigan, South Carolina, and Vermont).



Louis Farrakhan,

Born: May 11, 1933, Bronx, New York, N.Y., U.S.

- African American leader (1978–2007) of the Nation of Islam, an African American movement that combined elements of Islam with black nationalism.
- Was responsible for the million-man march in 1995



Colin Powell

Born: April 5, 1937, New York, New York, U.S.

Died: October 18 2021

- U.S. general and statesman
- chairman of the Joint Chiefs of Staff (1989–93)
- secretary of state (2001–05), the first African American to hold either position

Clarence Thomas

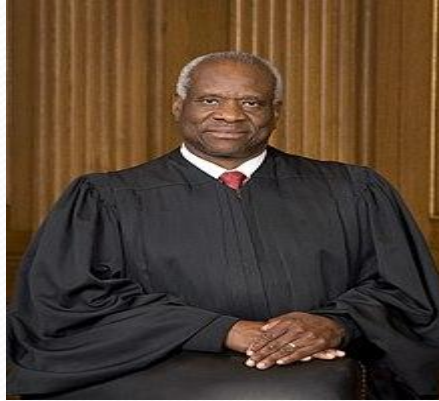

- **Clarence Thomas** (born June 23, 1948) is an American lawyer who serves as an **associate justice of the U.S. Supreme Court**. He was **nominated** by President **George H. W. Bush** to succeed **Thurgood Marshall** and has served since 1991.
- Thomas is the second **African American** to serve on the Court after Marshall. Since 2018, Thomas has been the senior associate justice, the longest-serving member of the Court, with 30 years.



Condoleezza Rice

Born: Nov. 14, 1954, Birmingham, Alabama, U.S.

- American educator and politician who served as national security adviser (2001–05) and secretary of state (from 2005) to Pres. George W. Bush.
- At age 15, Rice entered the University of Denver. Although she had earlier considered a career as a concert pianist, she turned to international relations, earning a bachelor's degree in the field in 1974. She later obtained a master's degree (1975) in economics from Notre Dame and a doctorate (1981).

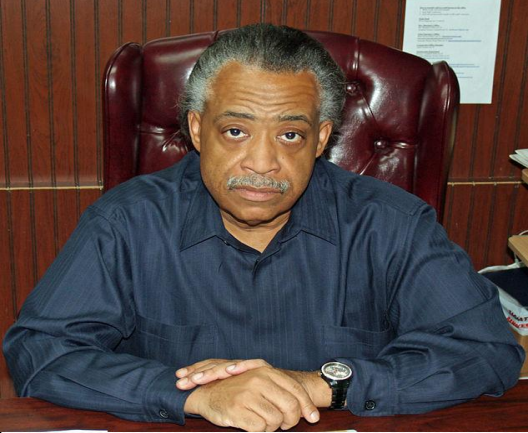

Al Sharpton

born October 3, 1954, Brooklyn, New York, U.S.

- civil rights activist and minister
- began preaching at age four and became an ordained Pentecostal minister at age 10. In 1971
- founded a national youth organization that promoted social and economic justice for African Americans



He has inspired a generation of stars over the years known as a clean-cut actor who carefully chooses and scrutinizes his acting roles

Denzel Washington

Born: December 28, 1954, Mount Vernon, New York, U.S.

- Actor
- Popular with both black and white audiences
- Known for playing clean moral roles
- Said to be an international sex symbol
- Graduated from Fordham University (B.A., 1977)
- Won an Oscar in the movie “Glory.”



Great philanthropists has given to a plethora of causes over the years

Oprah Winfrey

Born: January 29, 1954, Kosciusko, Mississippi, U.S.

- television personality,
- actress,
- entrepreneur whose syndicated daily talk show was among the most popular of the genre. She
- became one of the wealthiest and most influential women in the United States.

Spike Lee a famous movie producer



- Shelton Jackson "Spike" Lee (born March 20, 1957) is an American film director, producer, screenwriter, actor, and professor. His production company, 40 Acres and a Mule Filmworks, has produced more than 35 films since 1983. He made his directorial debut with *She has to Have It* (1986). He has since written and directed such films as *Do the Right Thing* (1989), *Mo' Better Blues* (1990), *Jungle Fever* (1991), *Malcolm X* (1992), *Crooklyn* (1994), *Clockers* (1995), *25th Hour* (2002), *Inside Man* (2006), *Chi-Raq* (2015), *BlacKkKlansman* (2018) and *Da 5 types of blood* (2020). Lee also acted in ten of his films.

couldn't find work. Perry is a great **philanthropist** **who gives to many causes and** provides shelter for the homeless.



- **Tyler Perry** (born **Emmitt Perry Jr.**, September 13, 1969)^[1] is an American actor, director, producer, and screenwriter.^[2] He is the creator and performer of the **Madea** character, a stern older woman.^{[3][4][5]} Perry's films vary in style from orthodox filmmaking techniques to filmed productions of live stage plays. Many of his stage-play films have been subsequently adapted as feature films.
- Perry wrote and produced many stage plays during the 1990s and early 2000s. He also developed several television series, most notably *Tyler Perry's House of Payne*, which ran for eight seasons on **TBS** from 2006 to 2012. In 2011



Tiger Woods

Born: December 30, 1975, Cypress, California, U.S.

- golfer, who enjoyed one of the most outstanding amateur careers in the history of the game
- the first golfer of either African American or Asian descent to win the Masters Tournament; with his victory at the 2001 Masters,
- Woods became the first player to win the four significant golf tournaments—the Masters, the U.S. Open, the British Open, and the Professional Golfers' Association of America (PGA) Championship consecutively.



Dr. Ben Carson

Born : September 18, 1951 (1951-09-18) (age 56)

Detroit Michigan Nationality United States Occupation Neurosurgeon

Religious beliefs Seventh-day Adventist Spouse Candy Carson

- Noted neurosurgeon.
- became the Director of Pediatric Neurosurgery at Johns Hopkins Hospital when he was 33 years old.
- Famous quote “listen to people who have already been where you want to go. Benefit from their mistakes instead of repeating them”
- Served as the secretary of housing under President Donald Trump



Barack Obama, Jr

Born: August 4, 1961).

Honolulu, Hawaii

- A graduate of Columbia University and Harvard Law School,
- Obama worked as a community organizer, university lecturer, and civil rights lawyer before
- Ran for public office and served in the Illinois Senate from 1997 to 2004. After an unsuccessful bid for a seat in the U.S. House of Representatives in 2000, he announced his campaign for U.S. Senate in 2003.
- Serviced as the first black president from 2008 to 2016

Reverend William Barber Civil Rights and Moral Monday leader



- **Moral Mondays** are protests that originated in [North Carolina, United States](#), and emerged elsewhere in the United States. Led by religious progressives, the leaders of the protesters sought to restore “morality” in the public sphere. Protests began in response to several actions by the government of North Carolina, which was elected into office in 2013, and are characterized by [civil disobedience](#)—specifically entering the state legislature building to be peacefully arrested.

Lloyd James Austin III the first black to serve as the Secretary of Defense



- **Lloyd James Austin III** (born August 8, 1953) is an American retired **United States Army four-star general** who, since his appointment on January 22, 2021, has served as the 28th **United States secretary of defense**. He is the first **African American** to serve as the United States secretary of defense. Austin previously served as the 12th commander of **United States Central Command** (CENTCOM) from 2013 to 2016.

Ketanji Brown Jackson was the first black woman to serve as an associate justice on the United States Supreme Court



- **Ketanji Brown Jackson** (born **Ketanji Onyika Brown**; September 14, 1970)^[2] is an American attorney and jurist who has served as a federal judge on the United States Court of Appeals for the District of Columbia Circuit since 2021.^[3] She is an associate justice-designate of the Supreme Court of the United States.

Brown received Senate confirmation on April 7, 2022, with all 50 members of the Democratic caucus and 3 Republicans voting in favor of the nomination, and 47 Republicans voting against.^{[4][5]}



AFRICAN-AMERICAN INVENTIONS



ALMANAC
PHILIP BRUCE ARMSTRONG



BABY BUGGY
MORDEcai RANDOLPH



BLOOD PLASMA BAG
MORDEcai RANDOLPH



CELLULAR CAR PHONE
MORDEcai RANDOLPH



CORN HARVESTER
MORDEcai RANDOLPH



ELEVATOR
MORDEcai RANDOLPH



ELECTRIC LAMP
MORDEcai RANDOLPH



EMERGENCY FIRE ESCAPE MECHANISM
MORDEcai RANDOLPH



FIRE EXTINGUISHER
MORDEcai RANDOLPH



GAS MASK
MORDEcai RANDOLPH



GUITAR
MORDEcai RANDOLPH



ICE CREAM
MORDEcai RANDOLPH



IMAGING X-RAY
MORDEcai RANDOLPH



LAWN MOWER
MORDEcai RANDOLPH



MAILBOX
MORDEcai RANDOLPH



MOP
MORDEcai RANDOLPH



PEANUT BUTTER
MORDEcai RANDOLPH



POTATO CHIP
MORDEcai RANDOLPH



RETASCHENDING COMB
MORDEcai RANDOLPH



TRAFFIC LIGHT
MORDEcai RANDOLPH

George Crum invented the potato chip

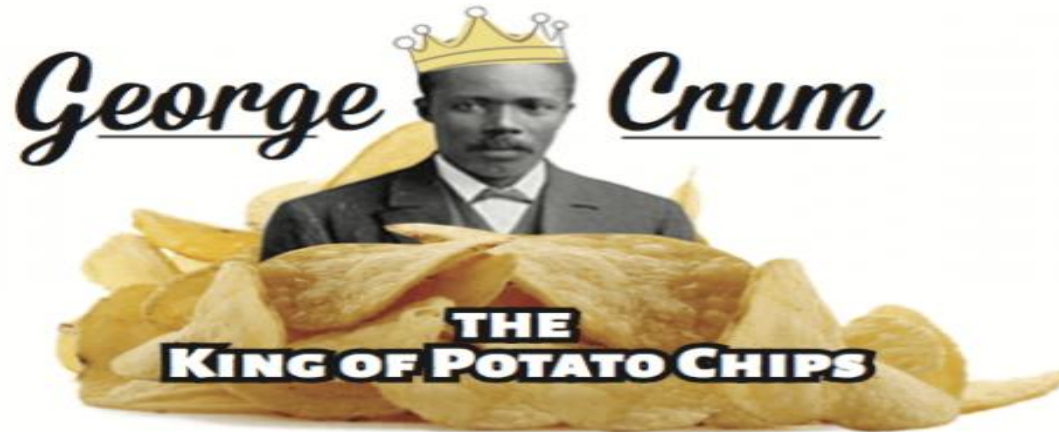

George Crum

George Speck, later known as George Crum and long thought to be the inventor of the potato chip, was born on July 15, 1824, in Saratoga County, New York, to parents Abraham Speck, an



Lewis Latimer

- Lewis Latimer (1848–1928) invented an essential part of the light bulb — the carbon filament.
- **Fast Fact:** Latimer worked in the laboratories of both Thomas Edison and Alexander Graham Bell.



Augustus Jackson called the father of modern ice cream



- After leaving the White House in the late 1820s, Jackson moved to Philadelphia and created his own successful catering business. He also developed **ice cream** flavors he packaged in tin cans and distributed to other ice cream parlors in Philadelphia. Jackson eventually became one of the city's wealthiest residents at the time.
- Now known as the "father of ice cream," Jackson pioneered some of its modern manufacturing methods, namely adding salt to the ice.^[1] Additionally, Jackson developed techniques to control the custard while it was freezing.^[2] There is no evidence that Jackson patented any of his recipes or techniques.^{[3][4]}
- By 1928, an article in *Capper's Weekly* attributed Jackson to making modern ice cream.^[5]



Elijah McCoy

- Elijah McCoy (1843–1929) invented an oil-dripping cup for trains.
- **Fast Fact:** Other inventors tried to copy McCoy's oil-dripping cup. But none of the other cups worked as well as his, so customers started asking for "the real McCoy." That's where the expression comes from.





Jan Ernst Matzeliger

- Jan Ernst Matzeliger (1852–1889) invented the shoemaking machine that increased shoemaking speed by 900%!
- **Fast Fact:** In 1992, the U.S. made a postage stamp in honor of Matzeliger.
- Jan Ernst Matzeliger (1852–1889) invented the shoemaking machine that increased shoemaking speed by 900%!
- **Fast Fact:** In 1992, the U.S. made a postage stamp in honor of Matzeliger.



granted a patent for his
version of the fire
extinguisher.

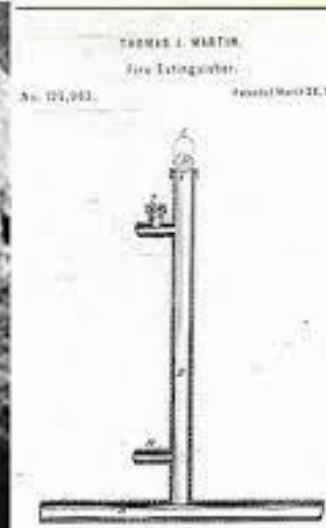

- **On March 26, 1872, Thomas J Martin, an African-American, was granted a patent for his version of the fire extinguisher. Martin's invention, listed in the U. S. Patent Office,**

Alexander Miles invented automatically opening and closing elevator doors.

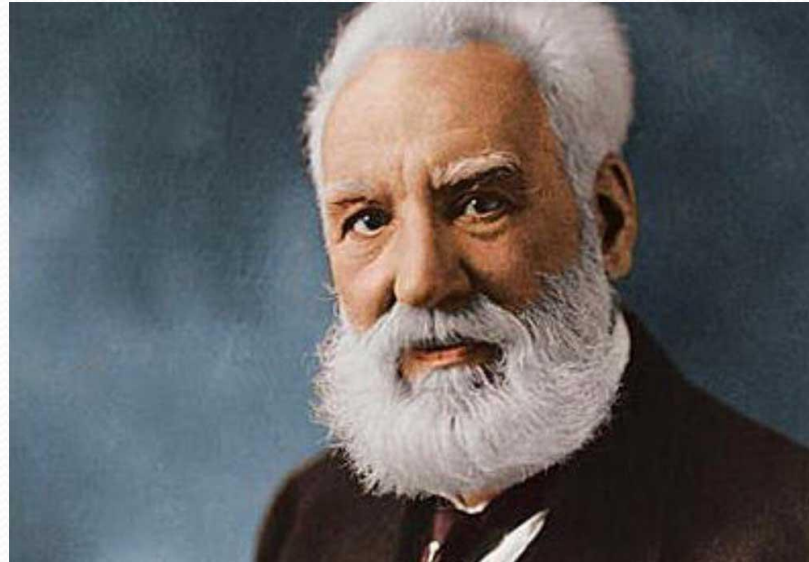

- **Alexander Miles was an African American inventor and businessman, best known for being awarded a patent for automatically opening and closing elevator doors. He was granted U.S. Patent 371,207 on October 11, 1887. Wikipedia**
- **Born: May 18, 1838, Ohio**

Robert Flemming the inventor of the modern guitar



Robert Flemming is recognized as the inventor of the modern-day acoustic guitar.

Henry Blair and created invented the corn seed planter.

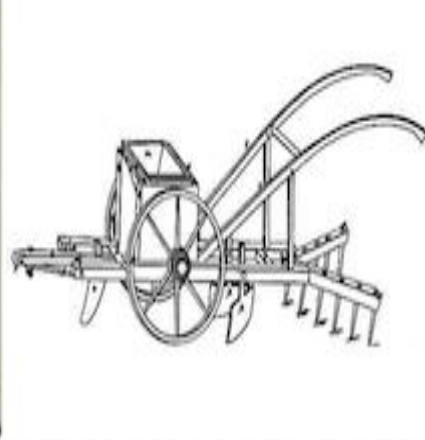

Henry Blair was the second African American to receive a patent on his invention. Blair, who was born in 1807, received his first patent on October 14, 1834, for his vision of the corn seed planter. It allowed the farmers to plant their corn much faster and with less labor. The machine also helped with weed control.



Granville T . Woods

Granville T. Woods (1856–1910) invented a train-to-station communication system.

- **Fast Fact:** Woods left school at age 10 to work and support his family.

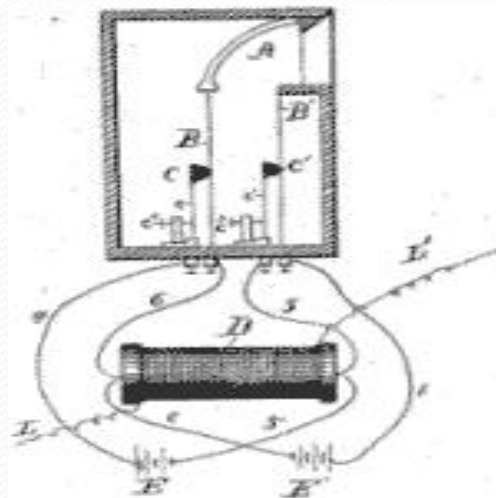

Thomas W Stewart received a patent for an improvement on the mop in 1893

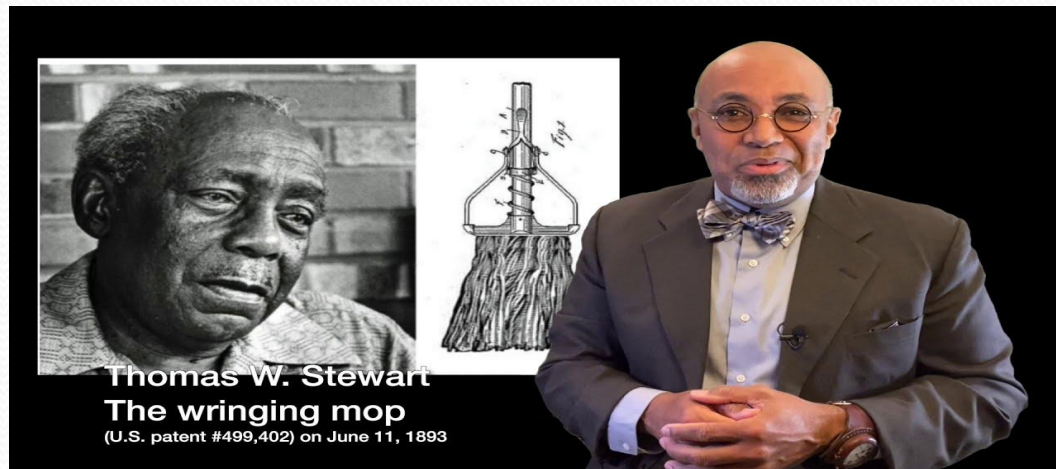

Thomas W. Stewart
The wringing mop
(U.S. patent #499,402) on June 11, 1893

- **Thomas W. Stewart**
- **A Black inventor who contributed to the advancement of the cleaning industry: Thomas W. Stewart. Stewart received a patent for his improvements to the mop in 1893, making him one of**

John Burr Patented the Rotary blade lawnmower.



John Burr was born in Maryland in 1848. His parents were enslaved people who were later freed, and he may also have been enslaved until age 17. He didn't escape from manual labor, as he worked as a field hand during his teenage years. As he began to understand mechanics, he worked to make a living repairing and servicing farm equipment and other machines. Wealthy black activists recognized his talent, and they ensured he could attend engineering classes at a private university. He moved to Chicago and also worked as a steelworker. When he filed his patent for the rotary blade mower in 1898, he lived in Agawam, Massachusetts.



George Washington Carver

- George Washington Carver (1860–1943) invented peanut butter and 400 plant products!
- **Fast Fact:** Carver was born into slavery. He didn't go to college until he was 30.





Madam C. J. Walker

- Madam C. J. Walker (1867–1919) invented a hair-growing lotion.
- **Fast Fact:** Walker grew up poor. But she became the first female African- American millionaire.





Garrett Morgan

- Garrett Morgan (1877–1963) invented the gas mask.
- **Fast Fact:** Morgan also invented the first traffic signal.



Did You Know A Black Man Invented The Reversible Baby Carriage?

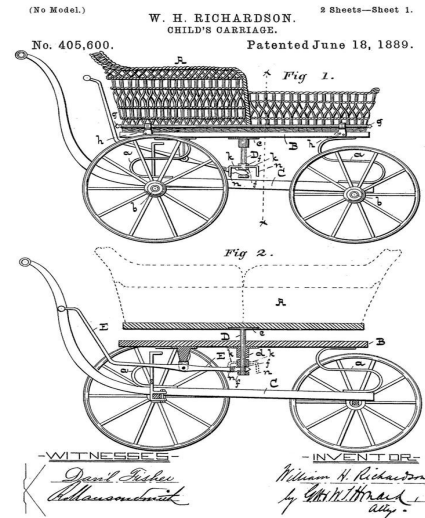

In 1899 William H Richardson patented a new type of baby carriage. His idea was to use a particular joint to allow a bassinet to face the operator. Several changes were made that allowed his carriage

John B Downing is credited with inventing the street letter box

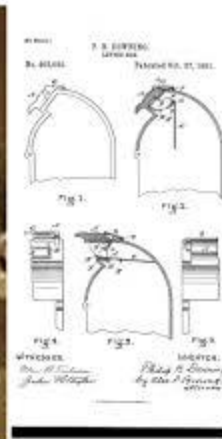

Philip B. Downing (1857-1934) was an African American inventor from [Providence, Rhode Island](#). He is best known for his two most significant inventions, the street letterbox and operating street railway switches. Philip had a long career in Boston, Massachusetts as a postal clerk. He retired in 1927 after working for more than thirty years. In the late nineteenth century and the early twentieth century, at least five patents were filed by Philip with the United States Patent Office. Their most significant and recognized inventions were the street letterbox and the operating street railway switches. Shortly after 1880, when Philip met and married Evangeline Howard, he had two children. Antonia Downing and Philip Downing Jr. The census records indicated Philip had moved to Boston, Massachusetts.



Otis Boykin

- **Otis Boykin** invented an improved electrical resistor used in computers - radios - television sets, and various electronic devices. Boykin's resistor helped reduce the cost of those products.
- Otis Boykin also invented a variable resistor used in guided missile parts, a control unit for heart stimulators, a burglar-proof cash register and
- a chemical air filter. After graduating from Fisk University and Illinois
- **Fast Fact:** Boykin invented 28 different electronic devices.

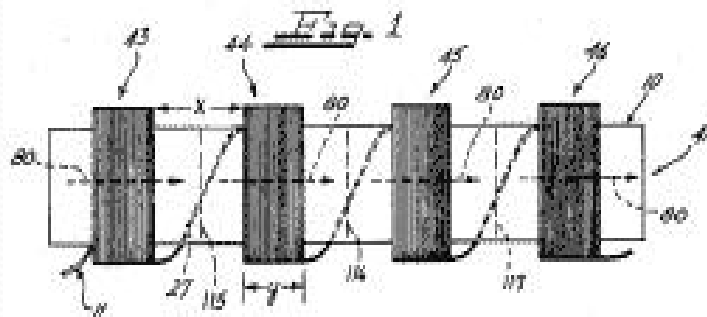

Jesse Russell digital cell phone inventor



- Russell was born on April 26, 1948, in Nashville, Tennessee. His family lived in an inferior and socially deprived part of Nashville. Fortunately, he got the opportunity to attend a summer education program at Fisk University, and he did exceptionally. Then, he moved on to study electrical engineering at Tennessee State University. He graduated with a Bachelor of Science degree in Electrical Engineering (BSEE). In 1973, Russell went further in his academic achievements to obtain a Master's degree in Electrical Engineering (MSEE) from Stanford University.
- While Russell was working as an engineer at AT&T-Bell Laboratories in 1988, he created the wireless digital phone and communication concept. At the time, mobile devices were mainly used in vehicles, so Russell designed a cell phone that could transmit signals between handsets and cell phone towers. Doing so would make mobile phones handier and also more affordable. In a statement, Russell once said, "Most of the time, people are not in their cars. I said, 'Well, that seems easy to solve. Why don't we take the phones out of the car and put them on the people.'"

Doctor Patricia bath invented a method of eye surgery known as laser surgery

Dr. Patricia Bath

- Dr. Patricia. E. Bath (1949–) invented a method of eye surgery (known as laser surgery) that has helped many blind people to see.
- **Fast Fact:** Dr. Bath has been nominated to the National Inventors Hall of Fame.







Lonnie G. Johnson

- **Lonnie G. Johnson**
- Lonnie G. Johnson (1949–) invented the world-famous water gun, the Super Soaker.
- **Fast Fact:** Johnson's company came out with a new Nerf ball toy gun.

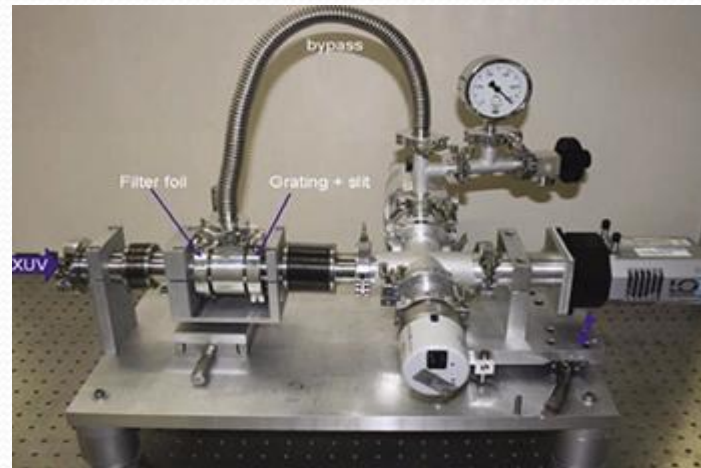

George Edward Alcorn invented the imaging X ray spectrometer



- Not many inventors have resumes as impressive as George Edward Alcorn's. The African-American inventor received a B.A. in physics, a master's degree in nuclear physics, and a Ph.D. in atomic and molecular physics. On top of that, Alcorn worked for Philco-Ford, Perkin-Elmer, IBM, and NASA, created over 20 different inventions, and was granted eight patents.
- Despite such impressive credentials, Alcorn is probably most famous for his innovation of the imaging x-ray spectrometer. This device helps scientists better understand what materials are composed of when they cannot be broken down. Receiving a patent for his method in 1984, Alcorn's inclusion of the thermomigration of aluminum  spectrometer was regarded as a significant innovation by experts in the field. The invention

Major civil rights events

Major Events of the Civil Rights Movement



The killing of Emmett Till



On August 28, 1955, a fourteen-year-old African American teenager was brutally murdered by white men while visiting relatives in Mississippi. His name was Emmett Till. His murder and the subsequent trial of his accused killers in 1955 became a lightning rod for moral outrage, both at the time and to this day. His killers were brought to go, but they were never convicted.

Sister Rosa Parks the mother of the modern day civil rights movement



Rosa Louise Parks was nationally recognized as the “mother of the modern-day civil rights movement” in America. Her refusal to surrender her seat to a white male passenger on a Montgomery, Alabama bus, on December 1, 1955, triggered a wave of protest on December 5, 1955, that reverberated throughout the United States. Her quiet, courageous act changed America’s views of racism and redirected the course of racial history in America.

Montgomery AL bus boycott



Community leaders called for a one-day bus boycott for December 5, her trial. When the boycott was a success, the leadership formed the Montgomery Improvement Association (MIA). They chose Dr. Martin Luther King Jr., a new community member, as their leader. At a mass meeting that evening, it was decided to continue the boycott. Thousands walked or found other means of travel for work, school, and shopping, and carpools were created. Drivers and passengers were often ticketed or arrested, and many boycott supporters were threatened with the loss of their jobs and harassed by local government officials. The boycott lasted 381 days; it was successful.

The freedom riders protested segregated buses throughout the South in the 1960s



- **Freedom Riders** were groups of white and African American civil rights activists who participated in bus Freedom Rides across state lines through the American

Freedom Riders vicious attack



- On Mother's Day, May 14, 1961, a Greyhound bus carrying Freedom Riders arrived at the Anniston, Alabama, bus station shortly after 1:00 pm to find the building locked shut. Led by Ku Klux Klan leader William Chapel, a mob of 50 men armed with pipes, chains, and bats, smashed windows, slashed tires, and dented the sides of the Riders' bus. Though warned hours

Doctor Martin Luther King Jr.



- **Martin Luther King Jr. was an American Baptist minister and activist who became the most visible spokesman and leader in the civil rights movement from 1955 until 1968. [Wikipedia](#)**
- **Born: January 15, 1929, Atlanta, GA**
- **Assassinated: April 4, 1968, Memphis, TN**
- **Spouse: Coretta Scott King (m. 1953–1968)**
- **Children: Martin Luther King III, Yolanda King, Bernice King, [Dexter King](#)**
- **Education: Boston**

Dr. Ralph Abernathy Dr. King's most prominent assistant



Ralph David Abernathy Sr. was an American civil rights activist and Baptist minister. He was ordained in the Baptist tradition in 1948. As a leader of the civil rights movement, he was a close friend and mentor of Martin

United States ambassador Andrew Young



- **Andrew Jackson Young Jr. is an American politician, diplomat, and activist. Beginning his career as a pastor, Young was an early leader in the civil rights movement, serving as executive director of the Southern Christian Leadership Conference and a close confidant of Martin Luther King Jr.** [Wikipedia](#)
- Young later served as the United States Ambassador to the United Nations under

1960 sit-in Greensboro demonstration



It was a protest to receive services in a Woodworth Restaurant setting that denied indoor service to African Americans. The protests served as a model for similar protests throughout America. The refusal to serve blacks inside public facilities in the South was eventually overturned.

James Meredith the first black student to attend the University of Mississippi



- James Meredith officially became the first African American student at the University of Mississippi on October 2, 1962. He was guarded twenty-four hours a day by reserve U.S. deputy marshals and army troops; he endured constant verbal harassment from a minority of students. On August 18, 1963, Meredith fulfilled his childhood dream to graduate from the University of Mississippi with a degree in political science.

Integration at the University of Mississippi—U.S. marshals accompanied James Meredith.



Medgar Wiley Evers' murder led President John F Kennedy to ask Congress for comprehensive civil rights legislation.

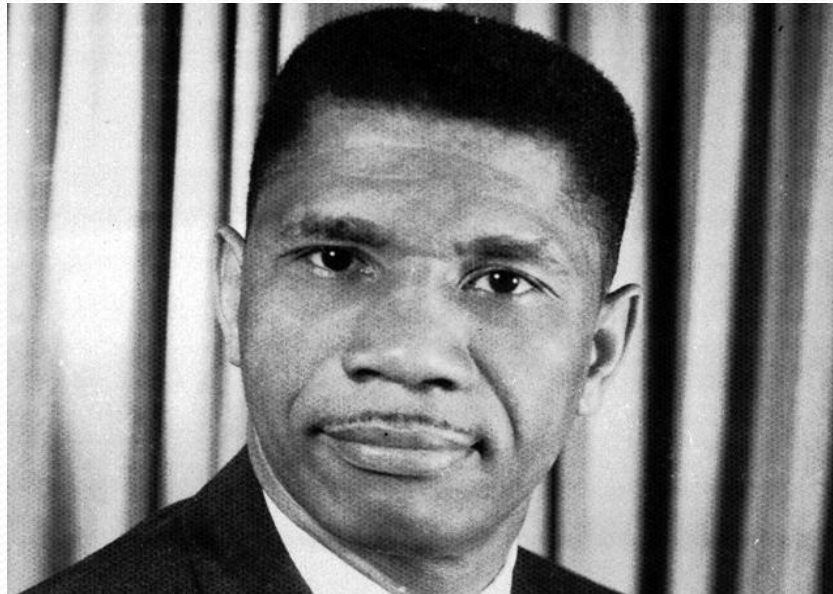

Medgar Wiley Evers is a civil rights campaigner and field secretary for the National Association for the Advancement of Colored People (NAACP), whose murder in 1963 prompted President John F. Kennedy to ask Congress for a comprehensive civil rights bill. Evers became the first martyr of the 1960s civil rights movement. His death was a turning point for many in the struggle for equality, infusing other civil rights leaders with

Birmingham, Alabama, May 14, 1963, the aftermath of the bombing at the Gaston Motel (Dr. Martin Luther King's headquarters)



Tuscaloosa, Alabama, June 11, 1963. Governor George Wallace attempted to block integration at the University of Alabama by "standing in the door"--scene outside Foster Auditorium



Washington, D.C., June 14, 1963. Attorney General Robert F. Kennedy speaks to a crowd of demonstrators at the Justice Department



Robert Kennedy, the brother of President John F Kennedy, became one of the most prominent supporters of civil rights legislation in America. He worked with Dr. Martin Luther King Jr. in achieving the objectives of civil rights.

Washington, D.C., August 28, 1963. Civil Rights March on Washington--looking toward the Washington Monument



- The **March on Washington for Jobs and Freedom**, also known as simply the **March on Washington** or **The Great March on Washington**,^{[1][2]} was held in [Washington, D.C.](#), on Wednesday, August 28, 1963.^[3] The purpose of the march was to advocate for African Americans' civil and economic rights. At the march, the final speaker Dr. [Martin Luther King Jr.](#), standing in front of the [Lincoln Memorial](#), delivered his historic "[I Have a Dream](#)" speech in which he called for an end to [racism](#).^[4]
- The march was organized by [A. Philip Randolph](#) and [Bayard Rustin](#), who built an alliance of civil rights, labor, and religious organizations^[5] under the banner of "jobs and freedom."^[6] Estimates of the number of participants varied from 200,000 to 300,000,^[7] but the most widely cited estimate is 250,000 people.^[8] Observers estimated that 75–80% of the marchers were black.^[9] The march was one of the largest [political rallies](#) for human rights in United States history.^[6] [Walter Reuther](#), president of the [United Auto Workers](#), was the most integral and highest-ranking white organizer of the march.^{[10][11]}
- The march is credited with helping to pass the [Civil Rights Act of 1964](#).^{[12][13]} It preceded the [Selma Voting Rights Movement](#) when national media coverage contributed to the passage of the Voting Rights Act of 1965.^[14](source Wikipedia)

Washington, D.C., August 28, 1963. Civil Rights March on Washington--march leaders, including Martin Luther King, walked abreast amid the crowd



The Selma to Montgomery Alabama protest marches



- The **Selma to Montgomery marches** were three protest marches held in 1965 along the 54-mile (87 km) highway from Selma, Alabama, to the state capital of Montgomery. Nonviolent activists organized the marches to demonstrate the desire of African-American citizens to exercise their constitutional right to vote in defiance of segregationist repression; they were part of a broader voting rights movement underway in Selma and throughout the American South. By highlighting racial injustice, they contributed to the passage of the Voting Rights Act, a landmark federal achievement of the civil rights movement.

After some soul searching and persuasion by Dr. Martin Luther King Jr., President John F Kennedy came around to support the civil rights movement.



- **John Fitzgerald Kennedy** (May 29, 1917 – November 22, 1963), often referred to by his initials **JFK**, was an American politician who served as the 35th president of the United States from 1961 until his assassination near the end of his third year in office.
- Kennedy served at the height of the Cold War, and the majority of his work as president concerning relations with the Soviet Union and Cuba. A Democrat, he represented Massachusetts in both houses of the U.S. Congress before his presidency.



- Johnson's civil rights legacy was shaped by signing the **Civil Rights Act of 1964**, the **Voting Rights Act of 1965**, and the **Civil Rights Act of 1968**. During his presidency, the American political landscape transformed significantly,^[4] as white southerners who were once staunch
- Democrats began moving to the **Republican Party**^[5], and **black voters** began moving to the Democratic Party.^{[6][7]} Because of his domestic agenda, Johnson's presidency marked the peak of **modern liberalism in the United States**.^[8]

Washington, D.C., April 11, 1968. President Lyndon Johnson signed the 1968 Civil Rights Bill surrounded by members of Congress. The 1968 act expanded on previous actions and prohibited discrimination concerning the sale, rental, and financing of housing based on race, religion, national origin, and since 1974, sex. Since 1988, the act has protected people with disabilities and families with children.



The face of the 1963 16th Street Baptist Church bombing in Birmingham, Alabama, was a regular meeting place for Dr. Martin King Jr. and his associates. The bombing and the killing of the four young girls led to a moral outrage throughout America and the world. It was a catalyst in passing various civil rights legislation.



Addie Mae Collins



Carole Robertson



Cynthia Wesley



Denise McNair

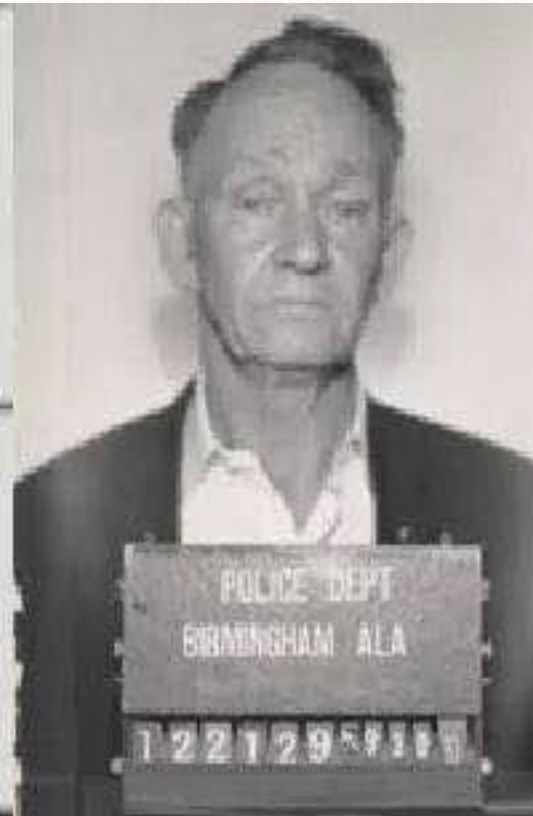

The Birmingham AL children's March(a protest for civil rights.) The image of dogs attacking children, fire hoses sprayed on them, and law enforcement making arrests was an embarrassment to America and throughout the world. The children's March made a profound impact on civil rights in America.



- The **Children's Crusade**, or **Children's March**, was a march by over 1,000 school students in **Birmingham, Alabama**, on May 2–3, 1963. Initiated and organized by Rev. **James Bevel**, the march's purpose was to walk downtown to talk to the mayor about segregation.
- Many children left their schools and were arrested, set free, and arrested the next day. The marches were stopped by the head of police, **Bull Connor**, who brought fire hoses to ward off the children and set police dogs after the children. This event compelled President **John F. Kennedy** to publicly support federal civil rights legislation and eventually led to the **Civil Rights Act of 1964**.

Washington, D.C., September 22, 1963. Congress of Racial Equality conducts a march in memory of the four girls killed in the Birmingham, Ala., Baptist church bombing



The bombing of 16th Street Baptist continues to shape and haunt perceptions of the South in national politics. Congress of Racial Equality conducts march in memory of children killed in Birmingham bombings, All Souls Church, 16th Street, Washington, DC, September 22, 1963. Photo by Thomas J. O'Halloran, courtesy of Wikimedia Commons and the Library of Congress.

The assassination of Doctor Martin Luther King Jr.



At 6:05 P.M. on Thursday, 4 April 1968, Martin Luther King was shot dead while standing outside his second-floor room at the Lorraine Motel in Memphis, Tennessee. News of King's assassination prompted major outbreaks of racial violence, resulting in more than 40 deaths nationwide and extensive property damage in over 100 American cities. James Earl Ray, a 40-year-old escaped fugitive, later confessed to the crime and was sentenced to a 99-year prison term. During King's funeral, a tape recording was played in which King spoke of how he wanted to be remembered after his death: "I'd like somebody to mention that day that Martin Luther King, Jr., tried to give his life serving others" (King, "Drum Major Instinct," 95).

Other tragic events that affected race relations in America



Nearly 400 black males were used to study untreated syphilis, of which 100 died. The victims were not informed of the nature of the experiment.

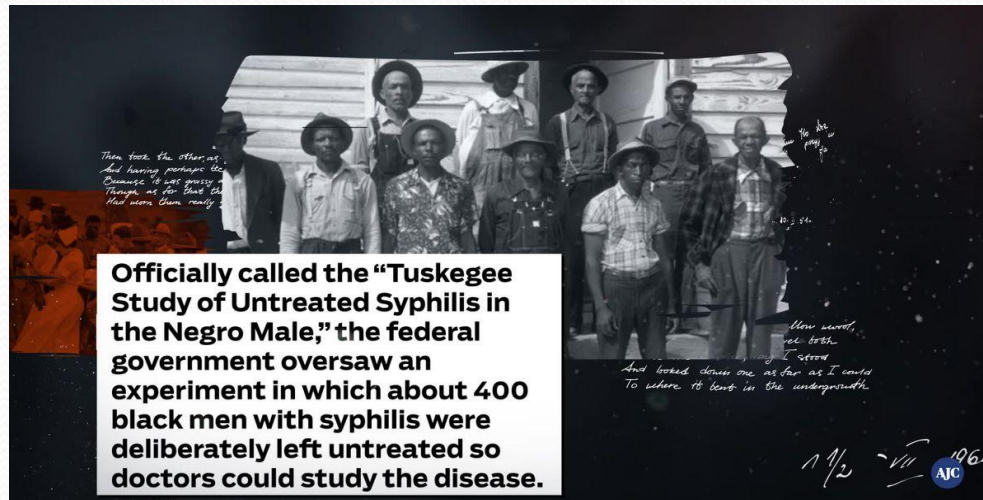

The **Tuskegee Study of Untreated Syphilis in the Negro Male**^{[1][2][3]} (informally referred to as the **Tuskegee Experiment** or **Tuskegee Syphilis Study**) was a study conducted between 1932 and 1972 by the **United States Public Health Service** (PHS) and the **Centers for Disease Control and Prevention** (CDC) on a group of nearly 400 **African Americans** with **syphilis**.^{[4][5]} The purpose of the study was to observe the effects of the disease when untreated, though, by the end of the study, medical advancements meant it was entirely treatable. The men were not informed of the nature of the experiment, and more than 100 died as a result.

Numerous Afro American women were targeted for Sterilizations between the 30s and the 70s



Sterilization of African-American women Of the 7,600 women sterilized by the state between 1933 and 1973, about 5,000 was African American. In light of this history, North Carolina became the first state to compensate surviving

The Killing and the unfair treatment of black men and women



5 cases that stand out are Rodney King, Trayvon Martin, Michael Brown, George Floyd, and Ahmaud Marquez Arbery

The Rodney King case (the officers were acquitted then the federal government brought charges where two officers were found guilty)



- **Rodney Glen King** (April 2, 1965 – June 17, 2012) was an African-American man who was a victim of **police brutality**. On March 3, 1991, King was beaten by **LAPD** officers during his arrest, after a high-speed chase, for driving while intoxicated on the **I-210**. An uninvolved individual, George Holliday, filmed the incident from his nearby balcony and sent the footage to local news station KTLA.^[2] The footage showed an unarmed King being beaten after initially evading arrest. The incident was covered by news media worldwide and caused blacks to complain for years about police brutality, but there was very little visible evidence.
- The videotaping of the savage beating of Rodney King got the attention of America.
- If there was no video evidence, would there have been any changes in the Los Angeles Police Department?
- The beating of Rodney King caused many African Americans to have a negative view of law enforcement. However, most law enforcement officers are law-abiding citizens.

The killing of Trayvon Martin



- On February 26, 2012, in [Sanford, Florida](#), United States, [George Zimmerman](#) fatally shot [Trayvon Martin](#), a 17-year-old [African-American](#) high school student. Zimmerman, a 28-year-old man of mixed race,^[Note 1] was the [neighborhood watch](#) coordinator for his [gated community](#) where Martin was visiting his relatives.^{[3][4][5]} Zimmerman shot Martin, who was unarmed, during a physical altercation. Zimmerman, injured during the encounter, claimed self-defense at his trial.
- In a widely reported trial, Zimmerman was charged with murder for Martin's death but acquitted at trial after claiming self-defense. The Department of Justice reviewed the incident for potential civil rights violations, but no additional charges were filed, citing insufficient evidence
- There was no video. Trayvon was walking through a Florida community. Zimmerman approached Trayvon a struggle ensued. Trayvon pinned Zimmerman to the ground. Zimmerman shot and killed Trayvon. Zimmerman was acquitted on a Florida stand your ground law. Black America, among many others, was outraged. It was noted that Zimmerman approached Trayvon. If Zimmerman had called law enforcement a community watchman and not come to Trayvon, what would have happened?

The killing of Michael Brown a 18 year old in Ferguson Missouri

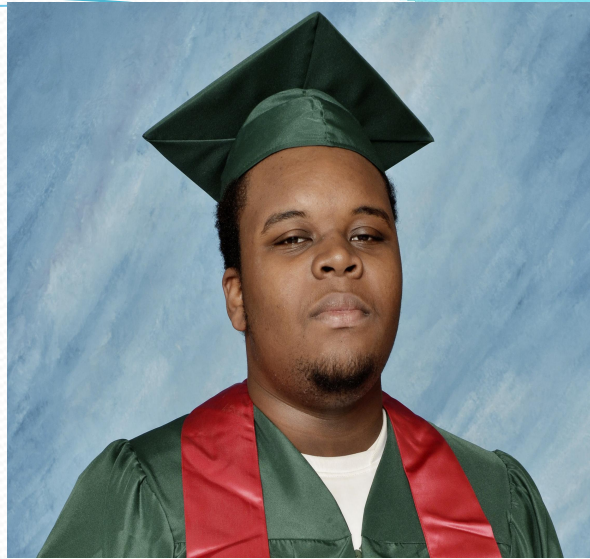

- *Darren Wilson resigned in November 2014, and a St. Louis County grand jury decided not to indict him. The U.S. Department of Justice found no grounds to prosecute Wilson. Still, the shooting led to a Justice Department investigation that resulted in a consent agreement requiring Ferguson to make significant changes to address racial bias in its police department and municipal court.*
- There was no video to confirm what happened in the Michael Brown case. The case received national attention, which led to comprehensive racial profiling changes within the Ferguson Police Department.

The chilling death of George Floyd George Floyd

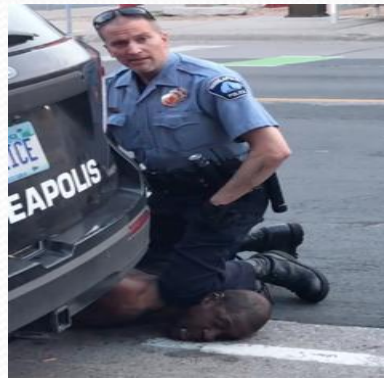

- Before being placed on the ground, Floyd had exhibited signs of anxiety, complaining about having **claustrophobia** and being unable to breathe.^[10] After being restrained, he became more distressed, still complaining of breathing difficulties and the knee on his neck and expressing fear of imminent death.^[5] After several minutes, Floyd stopped speaking.^[5] He lay motionless for the last couple of minutes, and Officer Kueng found no pulse when urged to check.^{[11][12]} Despite this, Chauvin ignored pleas from bystanders to lift his knee from Floyd's neck.^[13]
- The murder of George Floyd was on video for all to see. People throughout the world viewed the video. There was an international outcry for justice and law enforcement procedures. Justice was served due to the videotaping of the incident. The death of George Floyd has brought about national reforms in law enforcement protocol and procedures.

The murder of Ahmaud Marquez Arbery

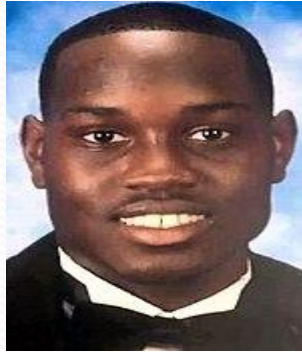

- On February 23, 2020, **Ahmaud Marquez Arbery** (born May 8, 1994), a 25-year-old Black man, was murdered in Satilla Shores, a neighborhood near [Brunswick](#) in [Glynn County, Georgia](#), United States.^{[3][4][5]} Arbery was jogging when three white men decided to pursue him: Travis McMichael and his father Gregory, armed and in one vehicle, and their neighbor, William "Roddie" Bryan, who was in another vehicle and recorded the pursuit and shooting on his cell phone. After several minutes, Travis McMichael got out of his truck and confronted Arbery with a shotgun; Travis shot Arbery three times after a physical confrontation. Arbery had entered an under-construction house five times, including once shortly before he was pursued. No evidence has emerged of Arbery committing any crimes.^{[3][4]}
- This was the situation where law enforcement should have been called if a crime was being committed. The videotaping of the event paved the way for a conviction in shooting an armed Black pedestrian.

The fatal shooting of Dante Wright



- On April 11, 2021, Dante Wright, a 20-year-old Black man, was fatally shot by police officer Kimberly Potter during a traffic stop and attempted arrest for an outstanding warrant in Brooklyn Center, Minnesota, United States. After a brief struggle with officers, Potter shot Wright in the chest once at close range. He drove off a short distance, but his vehicle collided with another and hit a concrete barrier. Officers administered CPR to Wright but could not revive him, and he was pronounced dead at the scene. Potter said she meant to use her service Taser, shouting, "Taser! Taser! Taser!"
- The prosecution asked for punishment within the sentencing guidelines. The judge reduced the sentence to the very minimum. The question is, would a person of color receive the same courtesy? The criminal justice system should be fair and objective.



The impact of black institutions

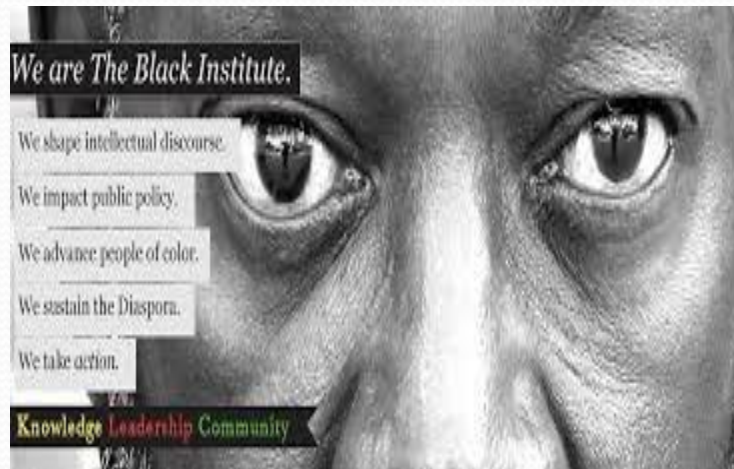

- The black family
- The church
- Black educational organizations
- Sports Icons
- Entertainment celebrities

The black family has endured many trials and tribulations

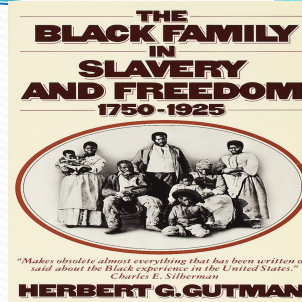

- The black American family is very complex. It is rooted in religion and slavery. Blacks have always been spiritual people believing in a higher power which goes back to their African roots. When one talks about the black American family, it goes back to slavery, when plantation owners separated husbands and wives from each other and their children. The white plantation owners had total control over black females and their husbands. Some blacks worked in the fields. Others worked in the homes; this set up an atmosphere of discrimination among many blacks. Mulattoes, part white, lived among the enslaved people; they generally were treated better than the enslaved Black people. There was friction in many families over skin color.
- Black mothers and fathers showed love to their children and raised them as best as possible in challenging circumstances. However, being mistreated, abused, separated, and treated like property still affects many blacks. Some blacks relish their history others feel victimized. Yet, overall the black family has made tremendous progress. They have made a significant contribution to the American success story.
- Blacks, by nature, are some of the most conservative people. This again is rooted in their African heritage, where it was all about friends and family.

Black church community impact



- Rooted in slavery, the black church has been at the forefront of support to enhance black Americans' lives. Enslaved people worked up from sunup to sundown. They had a short window to worship God between 6:00 pm Saturday to 6:00 am Monday.
- Some enslaved people had to steal away to praise and worship Jesus in an emotionally filled service giving thanks to God. After slavery, the church was one of the institutions representing black America; the preacher was looked on as one of the primary spokespeople. There were no political leaders and very few prominent leaders blacks could turn to for assistance.
- The church was not just a worship center but a social center where people came together and fellowship and socialized to see friends and family. The black church remains a vital institution in the black community. Doctor Martin Luther King Jr. came out of the black church. Many legendary entertainers, such as Aretha Franklin and Whitney Houston, got their start in church. Over the years, the black church became involved in politics because there was little or no black political representation in local and national government.

The Development of Black Leadership in the Schools

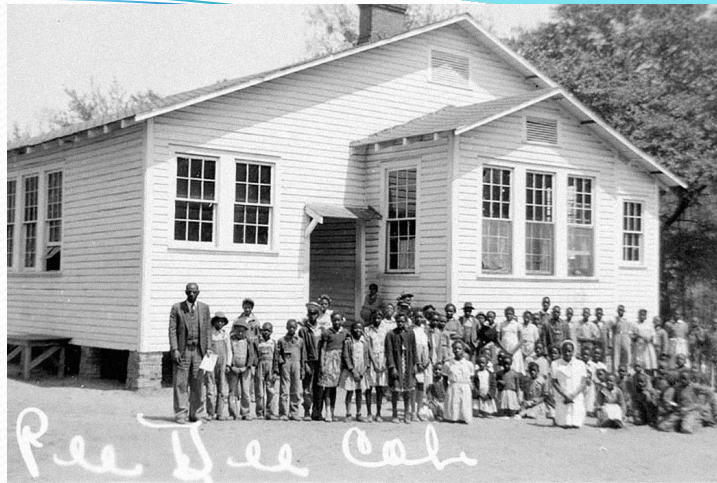

- Before integration, public schools and historically black colleges were institutions that developed leadership within the black community. Seeing black men and women in leadership positions had a profound effect on the self-esteem of black students. In addition, exposure to strong black role models inspired black students to take pride in their cultural heritage and have a respect for law and order. During the days of segregation, black teachers sponsored numerous service clubs, which helped develop leadership skills.
-
- Most of the professors, principals, teachers, and coaches who worked in the system during my childhood had respect for black and white communities. Several officials became long-term city mayors and councilmen upon retirement from the system. Over the years, the number of black leaders working in the school system has dramatically decreased. A lack of black leadership in responsible positions has significantly affected the black community.
-

The love affair and the impact of black sports icons



- From the very beginning, sports icons were idolized in the black community because they excelled in areas that had been blocked in the past. The idolizing goes back to Jack Johnson, the first black heavyweight champion leading up to Joe Louis, the brown bomber who defended his title more than any other heavyweight. Joe Louis was a source of inspiration and pride within the black community. Later, some great sports icons like Jim Brown, Bill Russell, and Kareem Abdul Jabbar became activists who stood against racism and social injustice. Muhammad Ali was probably the most prominent athlete who spoke out against social injustice. He was admired in the black community like none other than Jackie Robinson, who was respected because his courage and success in integrating Major League Baseball was a significant factor in integrating America.

Why We Have Black Entertainment Awards?



- For many years, blacks were given subservient acting roles; they were clowns, maids, butlers, airheads, and comic relief. Finally, Hollywood cast them as adult children who had no confidence, no education, no work ethic, and no courage during the early years.
- The media and the entertainment industry are responsible for any negative stereotypes that plagued black America for many years. Black actors and actresses were not cast as positive role models for black children during the early television and movie years. Blacks were not in wholesome, family-oriented programs. Discrimination in the movie industry hindered blacks from being recognized as great actors and actresses.
- Today, Black entertainers are some of the most admired icons in the black community. They are like athletes; they are looked at as those who beat the system. Many young people look at black entertainers as being role models. They seek to become well-known actors' actresses' singers' and writers in Hollywood producers. In addition, many blacks view the entertainment field as a way out of poverty to build generational wealth for their friends and family.

Cited works

All art and pictures are taken from Google images

Slide 1 the start of slavery in America. <https://www.history.com/topics/black-history/slavery>

Slide 2 Why slavery started?

<https://www.pbs.org/opb/historydetectives/feature/indentured-servants-in-the-us/>

Slide 3 How many slaves were brought to America?

<https://www.history.com/topics/black-history/slavery>

Slide 4 Where did most of the American slaves come from?

https://en.wikipedia.org/wiki/Atlantic_slave_trade

Slide 5 What were the conditions of the slaves on the slave ships?

<https://askinglot.com/what-were-the-conditions-on-slave-ships>

Slide 6 What were the conditions on the average plantation?

<https://treehozz.com/what-was-life-like-as-a-slave-on-a-plantation>

Cited works

All art and pictures are taken from Google images

Slide 7 3/5 of the slaves was were counted for taxation purposes
<https://www.britannica.com/topic/three-fifths-compromise>

Slide 8 slave uprising Nat Turner <https://www.evolution.com/prometheism-transhumanism-posthumanism/abolition-of-work/u-s-slavery-timeline-figures-abolition-history/>

Slide 9 Slave and Free State agreement Book source sound and fury page 10

Slide 10 Leaders who fought to abolish slavery <https://www.history.com/topics/black-history/slavery>

Slide 11 Sojourner Truth in Harriet Tubman were the two most prominent abolitionists https://en.wikipedia.org/wiki/Sojourner_Truth

Slide 12 John Brown's efforts to overthrow slavery [**John Brown's raid on Harpers Ferry - Wikipedia**](#)

Cited works

All art and pictures are taken from Google images

Slide 13 Distrust of law enforcement in the black community goes back to slavery source Michael J Darby jonah68@gmail.com

Slide 14 Slave catchers when someone over police force to track down escaped slaves https://en.wikipedia.org/wiki/Slave_catcher

Slide 15 The Dred Scott case <https://www.britannica.com/event/Dred-Scott-decision>

Slide 16 the Rodney King case https://en.wikipedia.org/wiki/Rodney_King

Slide 16 Abraham Lincoln

Slide 17 Abraham Lincoln the president who freed slaves
<https://www.history.com/topics/us-presidents/abraham-lincoln>

Slide 18 The war that freed the slaves

https://en.wikipedia.org/wiki/American_Civil_War

Cited works

All art and pictures are taken from Google images

Slide 19 The Emancipation Proclamation

<https://www.archives.gov/exhibits/featured-documents/emancipation-proclamation>

Slide 20 Juneteenth <https://en.wikipedia.org/wiki/Juneteenth>

Slide 21 https://en.wikipedia.org/wiki/Thirteenth_Amendment_to_the_United_States_Constitution

slide 22 https://en.wikipedia.org/wiki/Fourteenth_Amendment_to_the_United_States_Constitution

Slide 23 https://en.wikipedia.org/wiki/Fifteenth_Amendment

Cited works

All art and pictures are taken from Google images

- Slide 24 Southern reconstruction
<https://guides.lib.jjay.cuny.edu/c.php?g=288398&p=1922435#:~:text=Reconstruction%20refers%20to%20the%20period,the%20newly%20freed%20black%20population.>
- Slide 25 Freedmen's Bureau
https://en.wikipedia.org/wiki/Freedmen%27s_Bureau
- Slide 26 the end the reconstruction the beginning of the black code and Jim Crow laws
[https://en.wikipedia.org/wiki/Black_Codes_\(United_States\)](https://en.wikipedia.org/wiki/Black_Codes_(United_States))
- Slide 27 The Klan and white supremacy groups (Micheal J. Darby
jonah68@gmail.com

Cited works

All art and pictures are taken from Google images

Slide 28 The Klan prevented many productive law-abiding black citizens from building generational wealth (Micheal J. Darby) jonah68@gmail.com

Slide 29 the re enslavement of blacks
<https://www.pulitzer.org/winners/douglas-blackmon>

Slide 30 Blacks were well on their way to building a political dynasty until discriminations set in
<https://www.visitthecapitol.gov/exhibitions/timeline/image/first-colored-se>

Slide 31 The Mississippi Grand father clause law slowed black voting but did not totally eliminate it Race and Voting in the Segregated South (crf-usa.org)

[Slide 32 Hiram Revels](#) of Mississippi became the [first African American senator](#) in 1870. Born in North Carolina in 1827

https://www.senate.gov/senators/FeaturedBios/Featured_Bio_Revels.htm

Slide 33 Blanche K Bruce was the second black male elected to the Senate
https://www.senate.gov/senators/FeaturedBios/Featured_Bio_Bruce.htm

Cited works.

All art and pictures are taken from Google images

Slide 34 Edward Brooks was the first black senator elected in in the modern era more than 86 years after reconstruction (discriminatory Jim Crow laws did its job) https://www.senate.gov/senators/FeaturedBios/Featured_Bio_Brooke.htm

Slide 35 Major road -blocks prevented blacks from acquiring political capital following reconstruction until major civil rights legislation during the 1960s
Source: Micheal J. Darby jonah68@gmail.com

Slide 36 Major events that slowed black political and economic power
Source: Micheal J. Darby jonah68@gmail.com

Slide 37 Plessy versus Ferguson was a landmark 1896 U S Supreme Court decision that instituted legal discrimination under the guise of being separate and equal https://en.wikipedia.org/wiki/Plessy_v._Ferguson

Slide 38 The Plessy versus Ferguson case did not bring about equal opportunities are accommodations Source: Micheal J. Darby jonah68@gmail.com

Cited works

All art and pictures are taken from Google images

Slide 39 Brown versus the Board of Education Led to illegally overturning segregation which was illegally challenged it took years for it to become a reality
<https://www.history.com/topics/black-history/brown-v-board-of-education-of-topeka>

Slide 40 Lawyers behind the board the Brown versus Board of Education decision
<https://www.loc.gov/exhibits/brown/brown-brown.html>
<https://www.britannica.com/biography/Charles-Hamilton-Houston>

Slide 41 Continued barriers to building and black generational wealth

Slide 42 Widespread lynching
https://en.wikipedia.org/wiki/Lynching_in_the_United_States

Slide 43 Discrimination in the Home stead act
https://en.wikipedia.org/wiki/Homestead_Acts

Slide 44 The Wilmington massacre of 1898
https://en.wikipedia.org/wiki/Wilmington_insurrection_of_1898

Slide 45 Tulsa black Wall Street bombing
https://en.wikipedia.org/wiki/Tulsa_race_massacre

Cited works

All art and pictures are taken from Google images

Slide 46. Redlining

<https://www.investopedia.com/terms/r/redlining.asp#:~:text=Redlining%20is%20the%20discriminatory%20practice,on%20their%20race%20or%20ethnicity.&text=Redlining%20is%20most%20often%20associated,car%20loans%2C%20and%20personal%20loans.>

Slide 47 Benjamin Banneker https://en.wikipedia.org/wiki/Benjamin_Banneker

Slide 48 Crispus Attucks https://en.wikipedia.org/wiki/Crispus_Attucks

Slide 49 Phillis Wheatley https://en.wikipedia.org/wiki/Phillis_Wheatley

Slide 50 Sojourner Truth https://en.wikipedia.org/wiki/Sojourner_Truth

Slide 51 Harriet Tubman https://en.wikipedia.org/wiki/Harriet_Tubman

Slide 52 Underground railway Wikipedia

Slide 53 Frederick Douglass https://en.wikipedia.org/wiki/Frederick_Douglass

Cited works

All art and pictures are taken from Google images

Slide 54 George Washington https://en.wikipedia.org/wiki/George_Washington Carver George Washington Carver

Slide 55 Booker T. Washington https://en.wikipedia.org/wiki/Booker_T._Washington

Slide 56 W.E.B Du Bois https://en.wikipedia.org/wiki/W._E._B._Du_Bois

Slide 57 Matthew Alexander Henson https://en.wikipedia.org/wiki/Matthew_Alexander_Henson

Slide 58 Jack Johnson [https://en.wikipedia.org/wiki/Jack_Johnson_\(boxer\)](https://en.wikipedia.org/wiki/Jack_Johnson_(boxer))

Slide 59 Madam C. J. Walker https://en.wikipedia.org/wiki/Madam_C._J._Walker

Slide 60 Mary Mcleod Bethune
https://en.wikipedia.org/wiki/Mary_McLeod_Bethune

Cited works

All art and pictures are taken from Google images

Slide 61 Robert Robinson Taylor Wikipedia

Slide 62 Benjamin O. Davis, Sr.

https://en.wikipedia.org/wiki/Benjamin_O._Davis_Sr.

Slide 63 James Weldon Johnson

https://en.wikipedia.org/wiki/James_Weldon_Johnson

Slide 64 Carter G. Woodson https://en.wikipedia.org/wiki/Carter_G._Woodson

Slide 65 Bessie Coleman https://en.wikipedia.org/wiki/Bessie_Coleman

Slide 66 Langston Hughes https://en.wikipedia.org/wiki/Langston_Hughes

Slide 67 Marian Anderson

<https://search.yahoo.com/search?fr=mcafee&type=E210US105G0&p=Marian+Anderson>

Cited works

All art and pictures are taken from Google images

Slide 68 James Baldwin Wikipedia

slide 69 Maya Angelo Wikipedia

Slide 70 Charles Hamilton Houston

https://en.wikipedia.org/wiki/Charles_Hamilton_Houston

Slide 71 Joe Lewis Barrow https://en.wikipedia.org/wiki/Joe_Louis

Slide 72 Jesse Owens https://en.wikipedia.org/wiki/Jesse_Owens

Slide 73 Paul Robeson https://en.wikipedia.org/wiki/Paul_Robeson

Slide 74 Jackie Robinson https://en.wikipedia.org/wiki/Jackie_Robinson

Slide 75 The Tuskegee airmen

<https://search.yahoo.com/search?fr=mcafee&type=E210US105Go&p=The+Tuskegee+airmen>

Cited works

All art and pictures are taken from Google images

Slide 76 Ralph Johnson Bunche https://en.wikipedia.org/wiki/Ralph_Bunche

Slide 77 Rosa Parks https://en.wikipedia.org/wiki/Rosa_Parks

Slide 78 Thurgood Marshall https://en.wikipedia.org/wiki/Thurgood_Marshall

Slide 79 Dr. Martin Luther King Jr
https://en.wikipedia.org/wiki/Martin_Luther_King_Jr.

Slide 80 Malcolm X https://en.wikipedia.org/wiki/Malcolm_X

Slide 81 Alex Haley Wikipedia

Slide 82 Muhammad Ali https://en.wikipedia.org/wiki/Muhammad_Ali

Slide 83 James Brown Wikipedia

Cited works

All art and pictures are taken from Google images

Slide 84 Hidden NASA Heroines https://en.wikipedia.org/wiki/Hidden_Figures

Slide 85. Mary Jackson <https://www.nasa.gov/content/mary-w-jackson-biography>

Slide 86 Katherine Johnson <https://www.nasa.gov/feature/langley/katherine-johnson-s-stem-contributions-marked-on-her-103rd-birthday>

Slide 87 Dorothy Vaughn <https://www.britannica.com/biography/Dorothy-Vaughan>

Slide 88 Charles Bolden https://wamu.org/story/16/02/09/first_black_nasa_administrator_charles_bolden_pleaded_to_get_into_naval_academy/

Slide 87 Robert Robinson Taylor
https://en.wikipedia.org/wiki/Robert_Robinson_Taylor

Slide 88 John Hope Franklin https://en.wikipedia.org/wiki/John_Hope_Franklin

Slide 89 Shirley Chisholm Wikipedia

Slide 90 Reverend Jesse Jackson https://en.wikipedia.org/wiki/Jesse_Jackson

Cited works

All art and pictures are taken from Google images

Slide 91 Minister Lewis Farrakhan

<https://www.britannica.com/biography/Louis-Farrakhan>

Slide 92 General Colin Powell https://en.wikipedia.org/wiki/Colin_Powell

Slide 93 Clarence Thomas Wikipedia

Slide 94 Condoleezza Rice https://en.wikipedia.org/wiki/Condoleezza_Rice

Slide 95 Al Sharpton https://en.wikipedia.org/wiki/Al_Sharpton

Slide 96 Denzel Washington https://en.wikipedia.org/wiki/Denzel_Washington

Slide 97 Oprah Winfrey https://en.wikipedia.org/wiki/Oprah_Winfrey

Slide 98 Spike Lee Wikipedia

Slide 99 Tyler Perry Wikipedia

Slide 100 Tiger Woods https://en.wikipedia.org/wiki/Tiger_Woods

Cited works

All art and pictures are taken from Google images

Slide 94 Doctor Ben Carson

https://en.wikipedia.org/wiki/Ben_Carson

Slide 95 President Barack Obama

https://en.wikipedia.org/wiki/Barack_Obama

Slide 96 Reverend William Barber Wikipedia

Slide 97 Lord James Austin the 3rd Secretary of Defense
Wikipedia

Slide 98 Ketanji Brown Jackson Supreme Court Justice
Wikipedia

Cited works

All art and pictures are taken from Google images

- Slide 99 invention slide source Google images
- Slide 100 George Crum Wikipedia
- Slide 101 Lewis Latimer
https://en.wikipedia.org/wiki/Lewis_Howard_Latimer
- Slide 102 Augustus Jackson Wikipedia
- Slide 103 Elijah McCoy
https://en.wikipedia.org/wiki/Elijah_McCoy
- Slide 104 Jan Ernst Matzeliger
https://en.wikipedia.org/wiki/Jan_Ernst_Matzeliger slide
105 Thomas J Martin Wikipedia slide 106 Alexander Miles
Wikipedia

All art and pictures are taken from Google images

- Slide 107 Robert Fleming Wikipedia
- Slide 108 Henry Blair Wikipedia
- slide 109 Ernst_Matzeliger
https://en.wikipedia.org/wiki/Jan_Ernst_Matzeliger
- Slide 110 Granville T Woods
https://en.wikipedia.org/wiki/Granville_Wood
- Slide 111 Thomas W Stewart Wikipedia
- Slide 112 John Burr Wikipedia
- Slide 113 George Washington Carver
https://en.wikipedia.org/wiki/George_Washington_Carver
- Slide 114 Madam CJ Walker
https://en.wikipedia.org/wiki/Madam_C._J._Walker

Cited works

All art and pictures are taken from Google images

- Slide 115 Garrett Morgan
https://en.wikipedia.org/wiki/Garrett_Morgan
- Slide 116 William H Richardson Wikipedia
- Slide 117 John B Downing Wikipedia
- Slide 118 Otis Boykin Wikipedia
- Slide 119 Dr. Patricia Bath
https://en.wikipedia.org/wiki/Patricia_Bath
- Slide 120 Lonnie Johnson
[https://en.wikipedia.org/wiki/Lonnie_Johnson_\(inventor](https://en.wikipedia.org/wiki/Lonnie_Johnson_(inventor))
- Slide 122 George Edward Conwell Wikipedia
- Slide 123 Major civil rights events
<https://www.britannica.com/list/timeline-of-the-american-civil-rights-movement>

Cited works

All art and pictures are taken from Google images

Slide 124 The killing of Emmett Till https://en.wikipedia.org/wiki/Emmett_Till

Slide 125 Sister Rosa Parks

<https://www.rosaparks.org/biography/#:~:text=Rosa%20Louise%20Parks%20was%20nationally,reverberated%20throughout%20the%20United%20States.>

Slide 126 Montgomery AL bus boycott

<https://www.wesleyan.edu/mlk/posters/rosaparks.html>

Slide 127 Freedom Riders <https://www.history.com/topics/black-history/freedom-rides#:~:text=Freedom%20Riders%20were%20groups%20of,to%20protest%20segregated%20bus%20terminals.>

Slide 128 freedom rider bus attack

<https://www.smithsonianmag.com/history/the-freedom-riders-then-and-now-45351758/>

Slide 129 Dr. Martin Luther King Jr.

https://en.wikipedia.org/wiki/Martin_Luther_King_Jr.

Cited works

All art and pictures are taken from Google images

- Slide 130 Dr. Ralph Abernathy Sr.
https://en.wikipedia.org/wiki/Ralph_Abernathy
- Slide 131 United States ambassador Andrew young
https://en.wikipedia.org/wiki/Andrew_Young
- Slide 132 the 1960 Greensboro city and demonstration
<https://www.britannica.com/event/Greensboro-sit-in>
- Slide 133 James Meredith
<https://npg.si.edu/blog/september-30-1962-james-meredith-university-mississippi>
- Slide 134 James Meredith the integration at the University of Mississippi
<https://npg.si.edu/blog/september-30-1962-james-meredith-university-mississippi>
- Slide 135 Medgar Wylie Evers
<https://www.mec.cuny.edu/history/life-of-medgar-evers/>

Cited works

All art and pictures are taken from Google images

- Slide 136 the bombing of Gaston motel Dr. King's headquarters <https://www.nps.gov/articles/ag-gaston-motel-birmingham-civil-rights-monument.htm>
- Slide 137 George Wallace Wikipedia
- Slide 138 Attorney General Robert Kennedy https://en.wikipedia.org/wiki/Robert_F._Kennedy
- Slide 139 1963 civil rights March Washington https://en.wikipedia.org/wiki/March_on_Washington_for_Jobs_and_Freedom
- Slide 140 https://en.wikipedia.org/wiki/March_on_Washington_for_Jobs_and_Freedom

All art and pictures are taken from Google images

- Slide 141 Selma to Montgomery AL March
Wikipedia
- Slide 142 President John Fitzgerald Kennedy
Wikipedia
- Slide 143 President Lyndon Baines Johnson
Wikipedia
- Slide 144 President Lyndon Baines Johnson
send the 1968 civil rights bill Wikipedia
- Slide 145 the faces of the 1963 16th street Baptist
Church bombings in Birmingham AL
- Slide 146 the assassination of doctor king
Wikipedia

Cited works

All art and pictures are taken from Google images

Slide 129 other tragic events that affected race relations in America

Slide 130 The Tuskegee Study of Untreated Syphilis in the Negro Male

<https://pubmed.ncbi.nlm.nih.gov/9422551/>

Slide 131 Sterilization between the 30s and the 70s

https://en.wikipedia.org/wiki/Eugenics_in_the_United_States

Slide 132 Killing and the unfair treatment of black men and women

Slide 133 the beating of Rodney King very quickly they found Wikipedia Slide 133 The Killing Trayvon Martin

https://en.wikipedia.org/wiki/Killing_of_Trayvon_Martin

Slide 134 The killing of Michael Brown 18-year-old in Ferguson Missouri

https://en.wikipedia.org/wiki/Darren_Wilson

Cited works

All art and pictures are taken from Google images

Slide 135 The murder of George Floyd

https://en.wikipedia.org/wiki/Murder_of_George_Floyd

Slide 136 The murder of Ahmaud Marquez Arbery

https://en.wikipedia.org/wiki/Murder_of_Ahmaud_Arbery

Slide 137 The fatal shooting of Dante Wright

https://en.wikipedia.org/wiki/Killing_of_Daunte_Wright

